

Uzavretý regulačný obvod

Juraj Oravec

URO

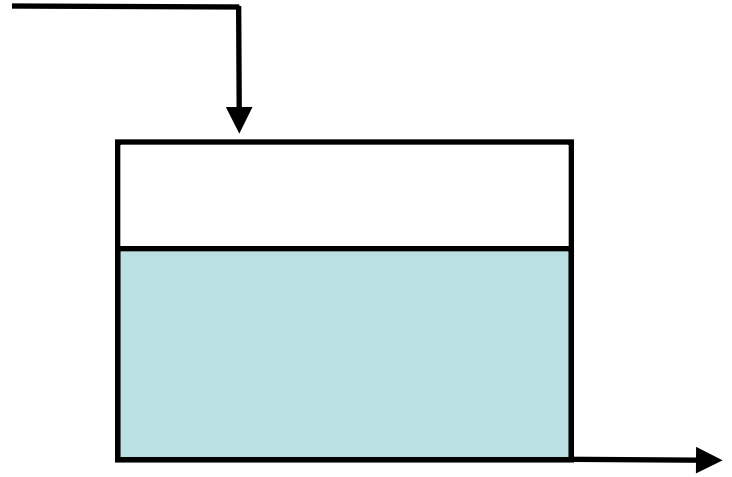

URO

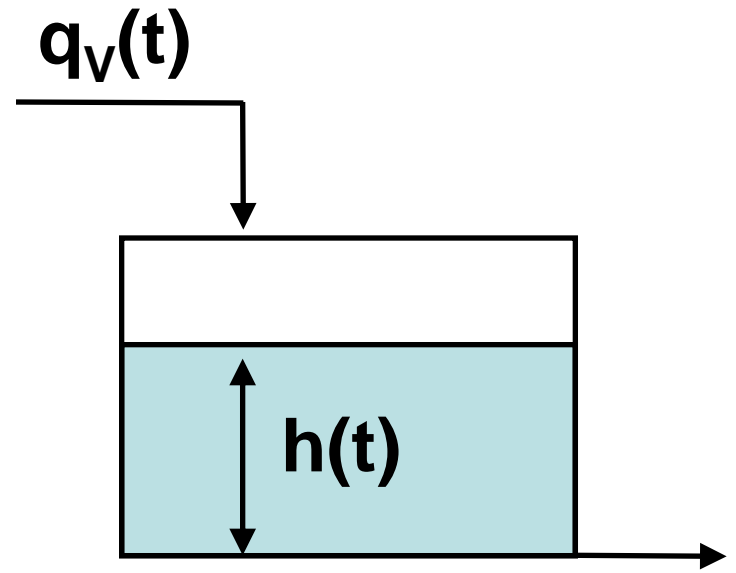

URO

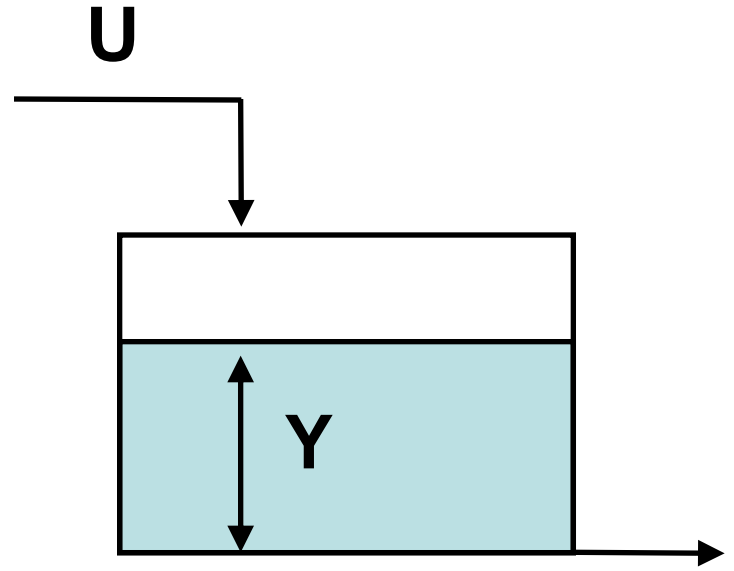

URO

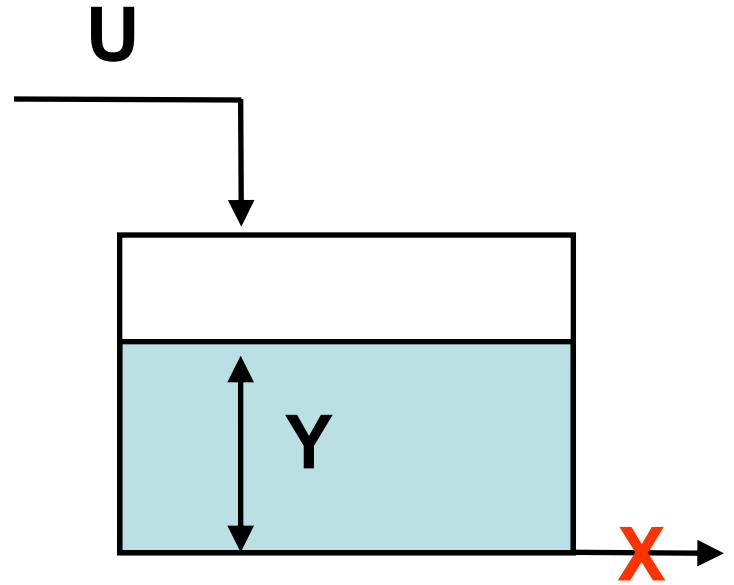

URO

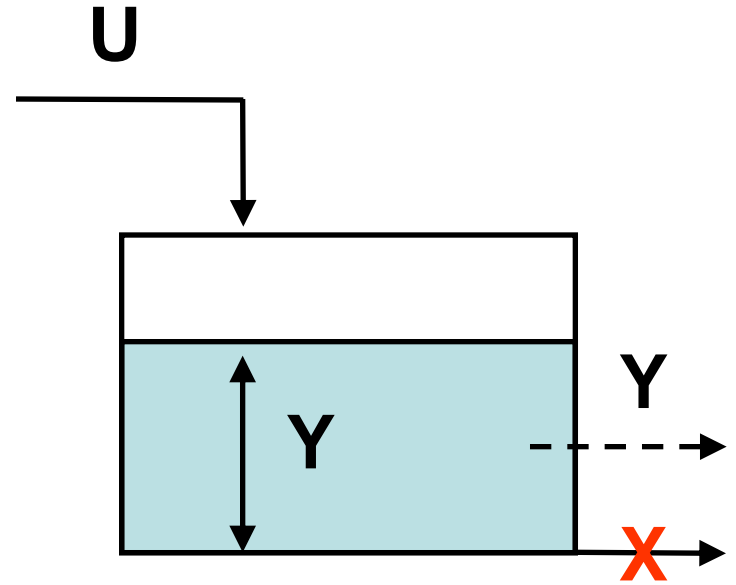

URO

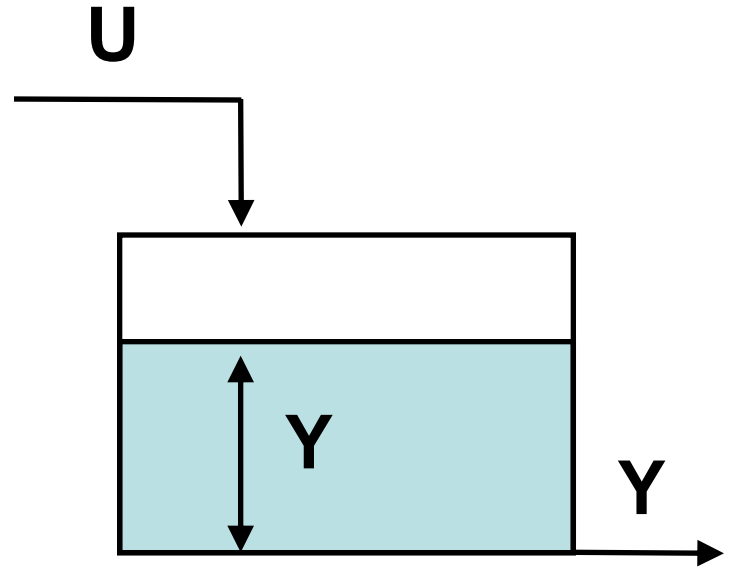

URO

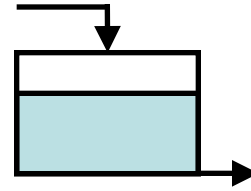

URO

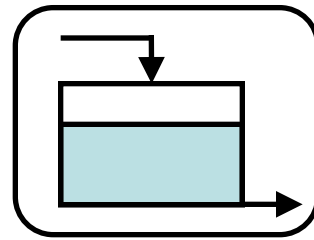

URO

proces

URO

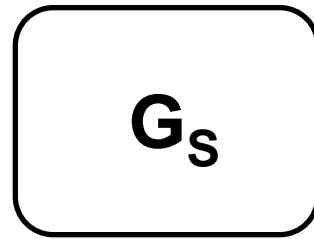

URO

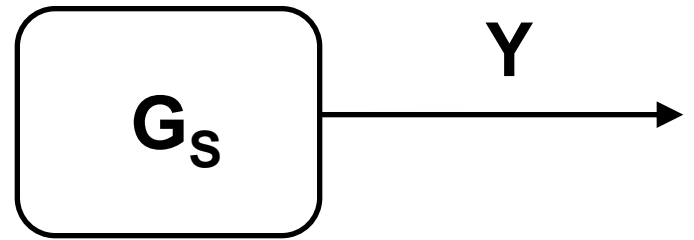

URO

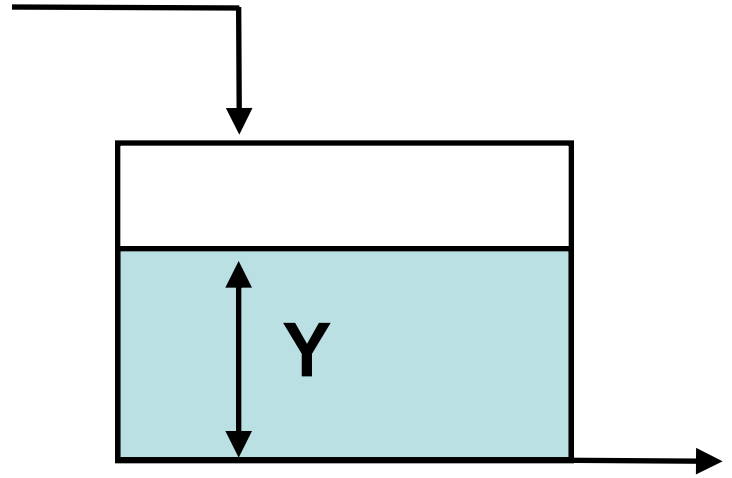

URO

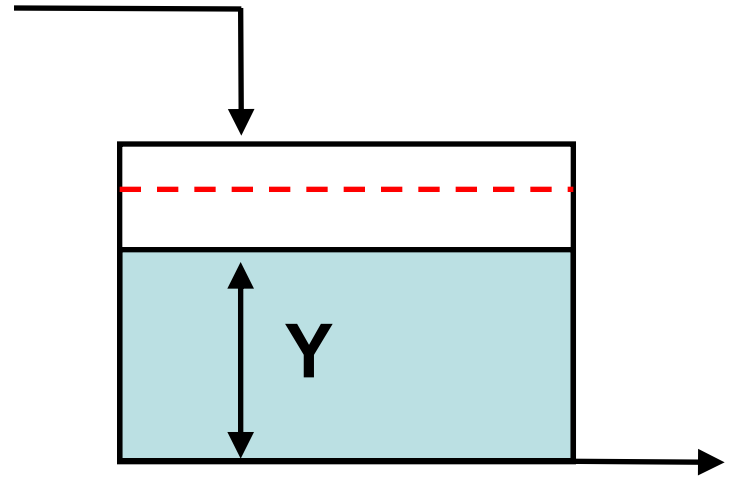

URO

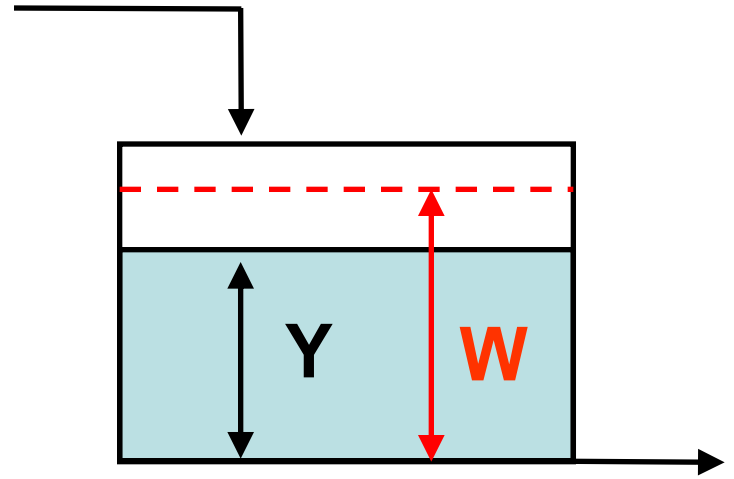

URO

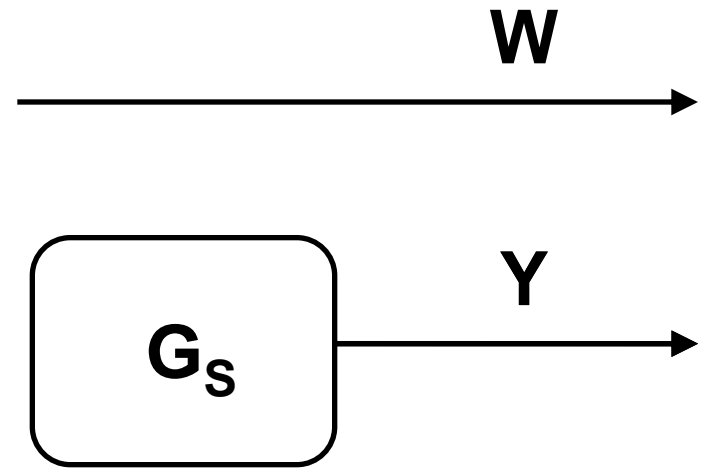

URO

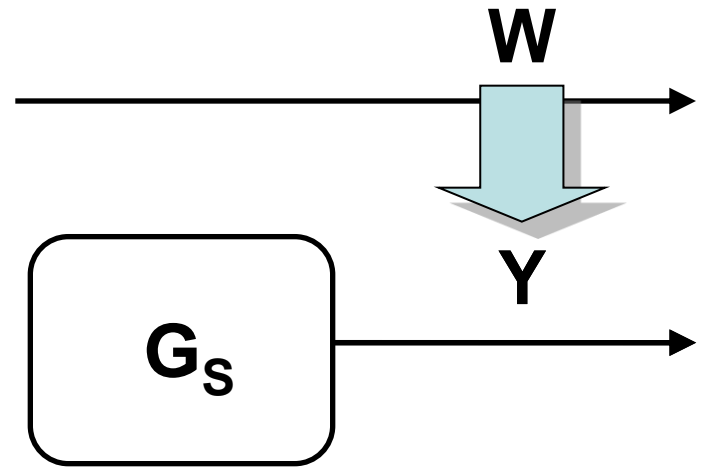

URO

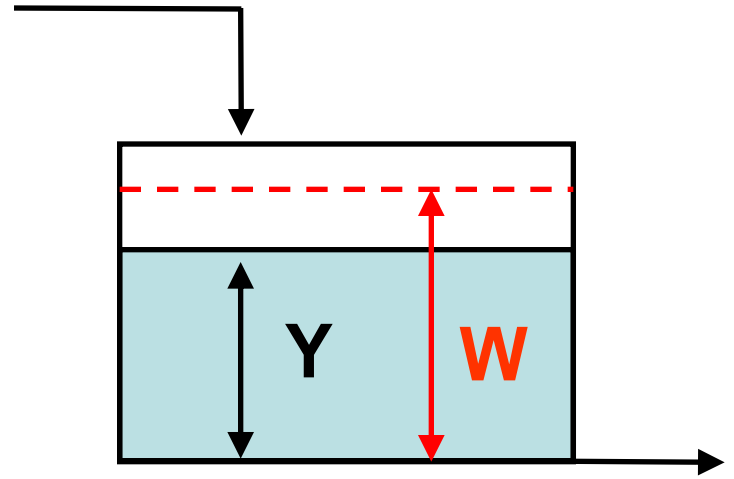

URO

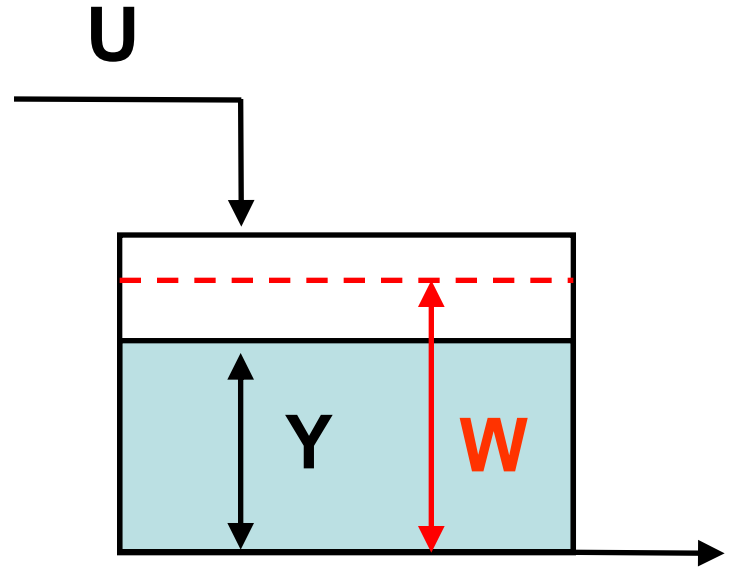

URO

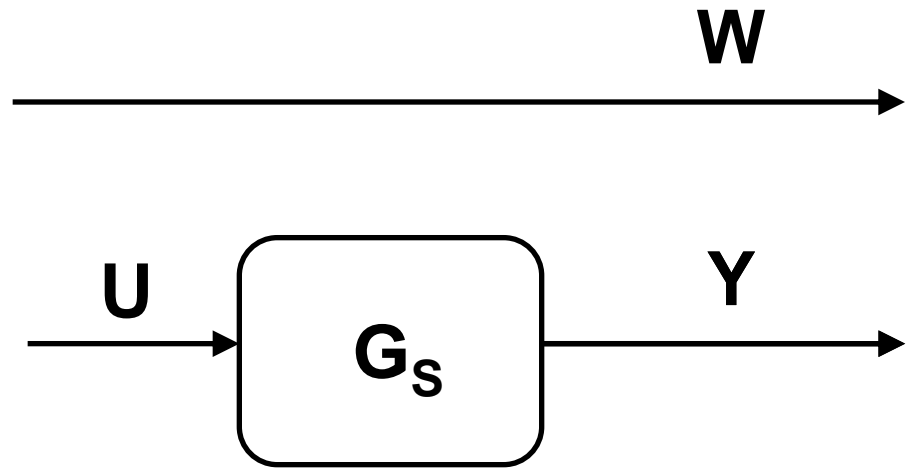

URO

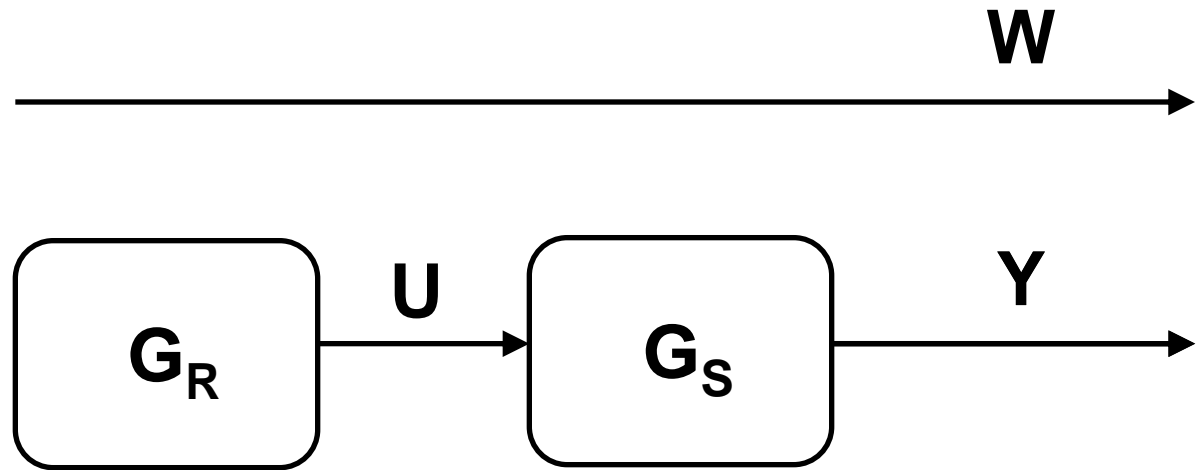

URO

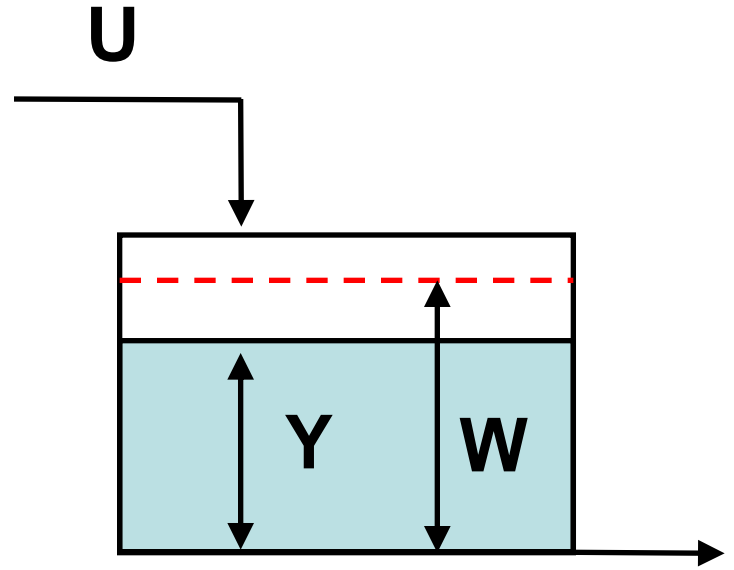

URO

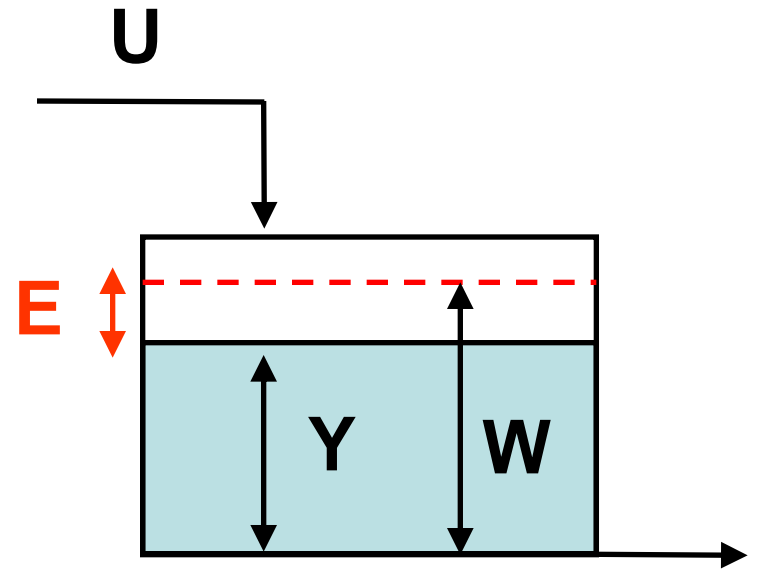

URO

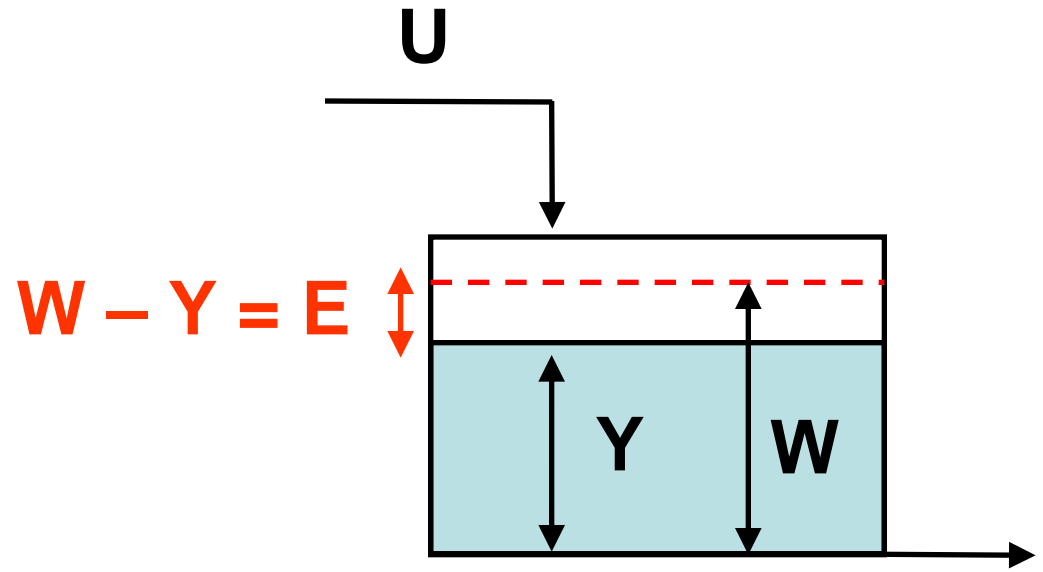

URO

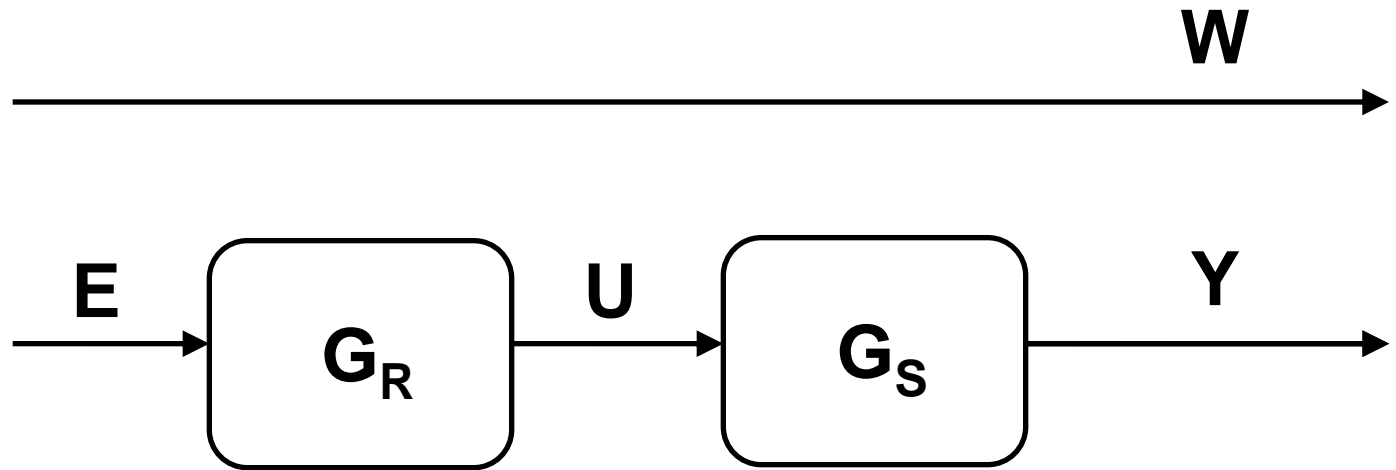

URO

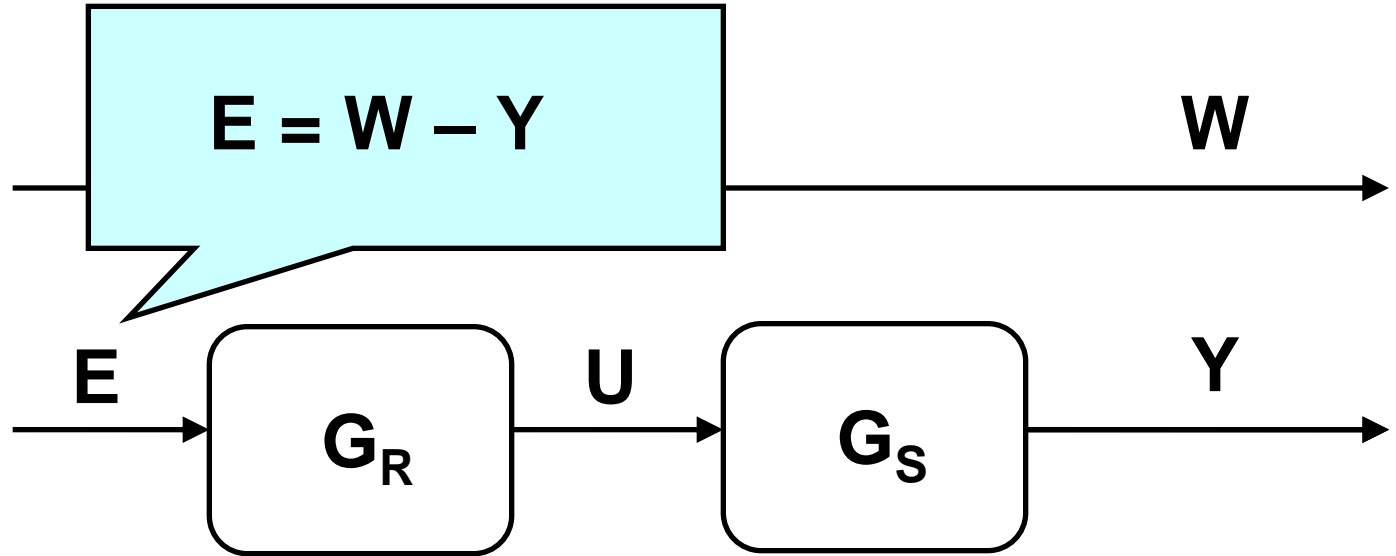

URO

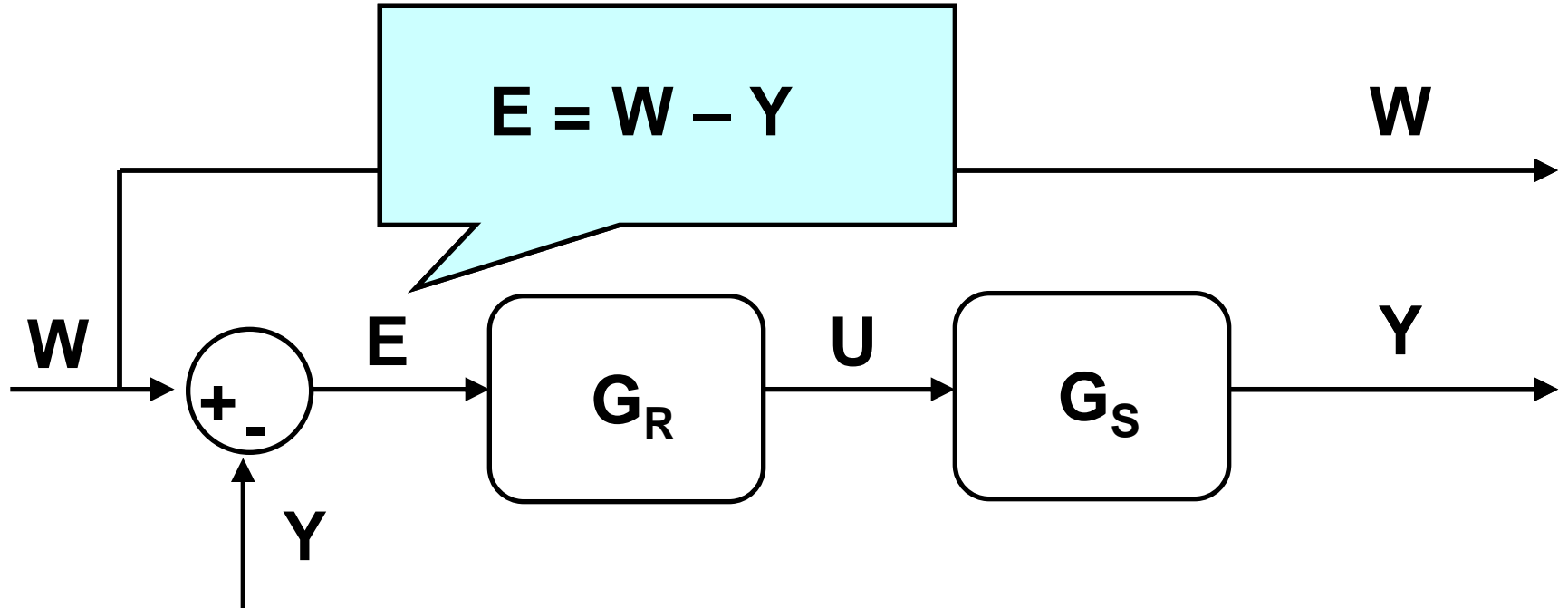

URO

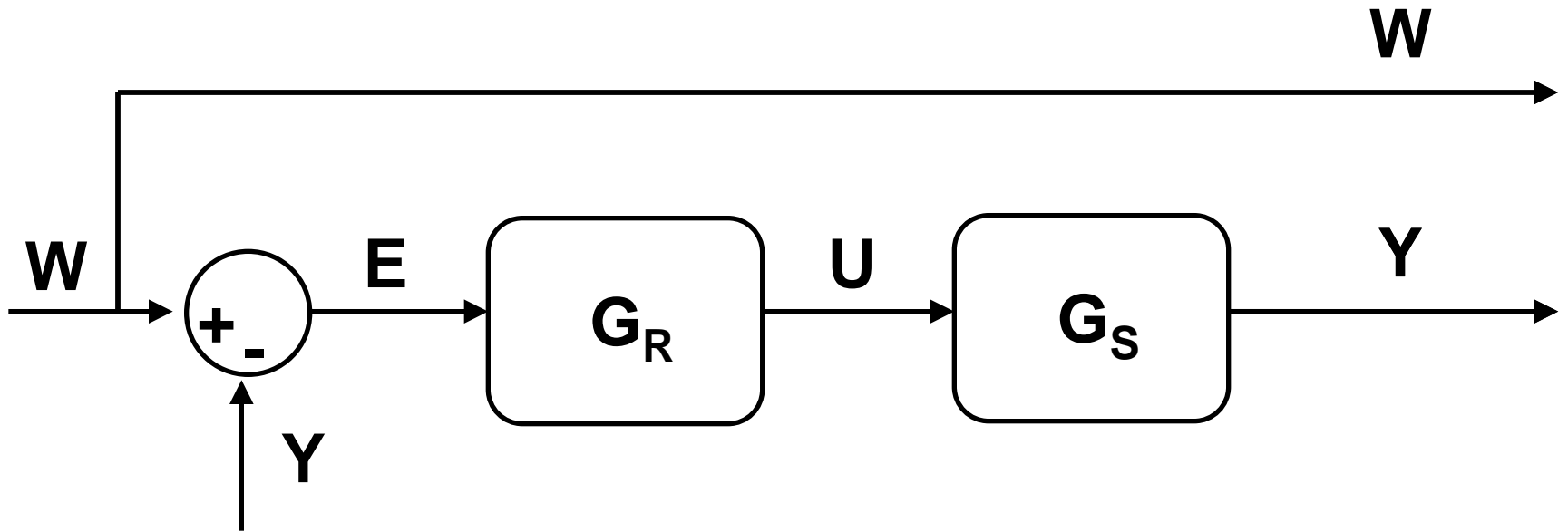

URO

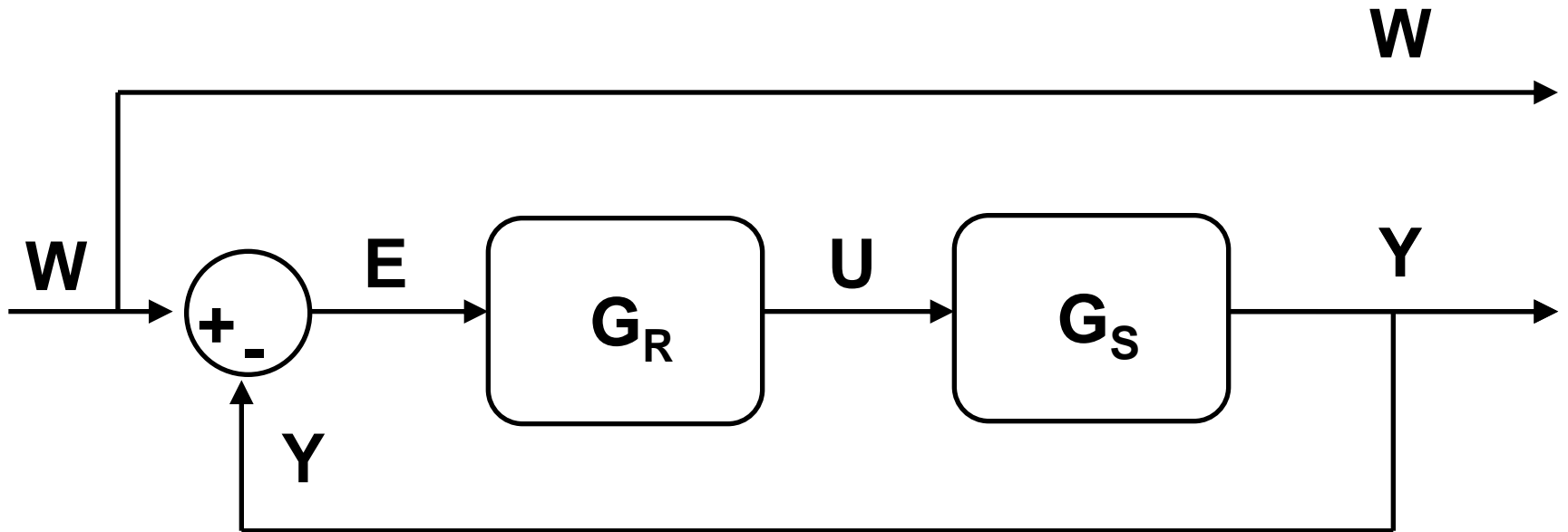

URO

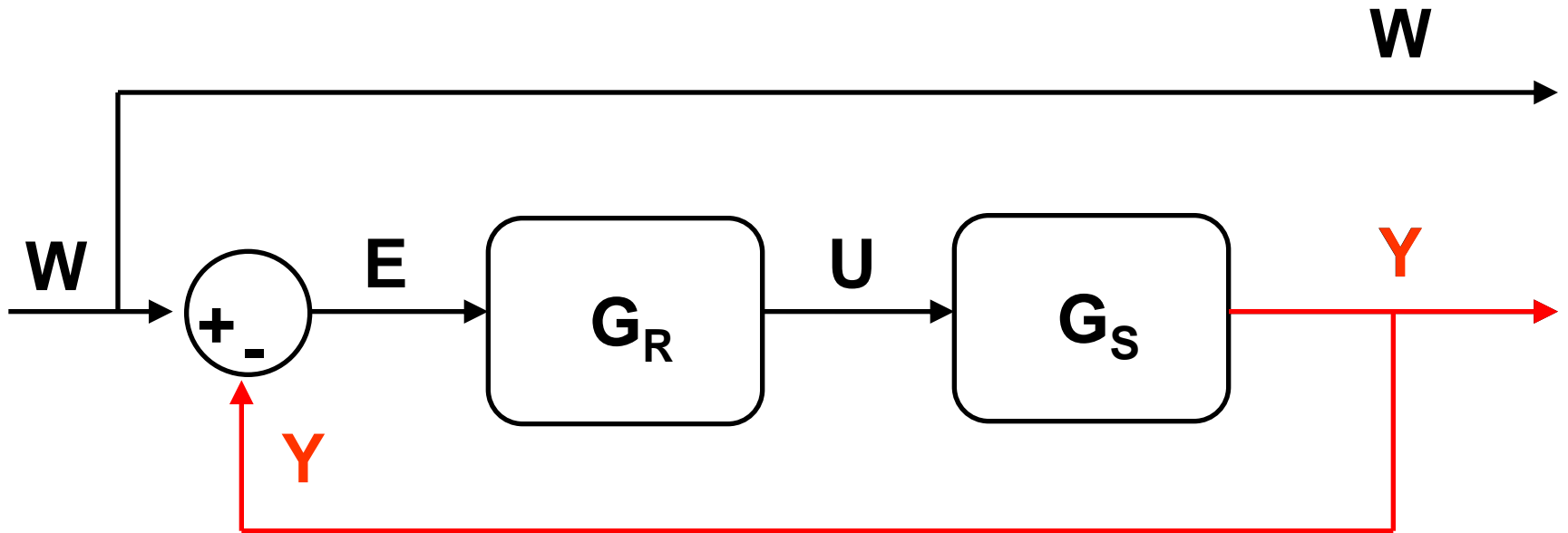

URO

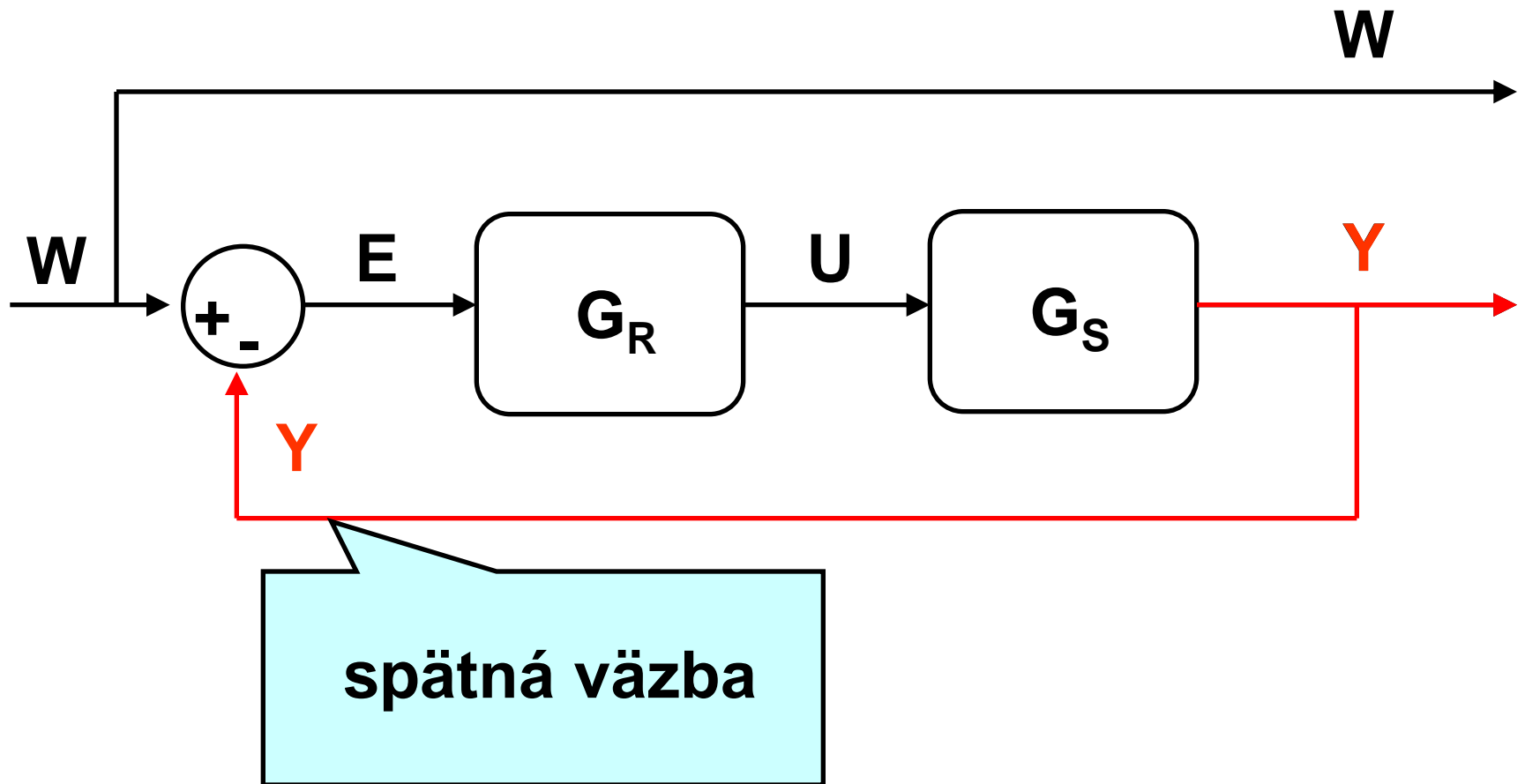

URO

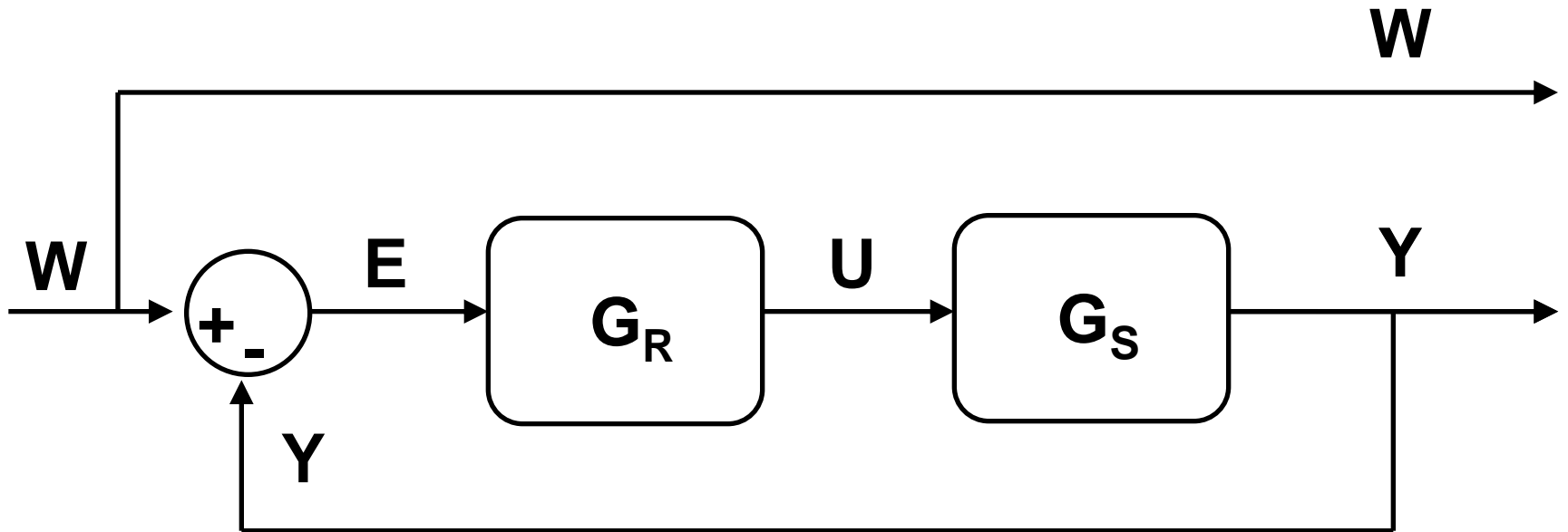

URO

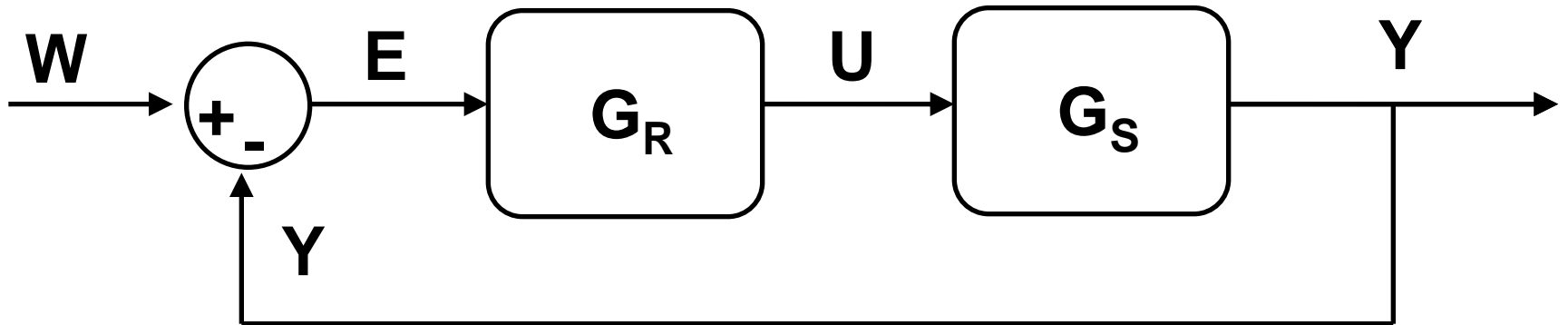

URO

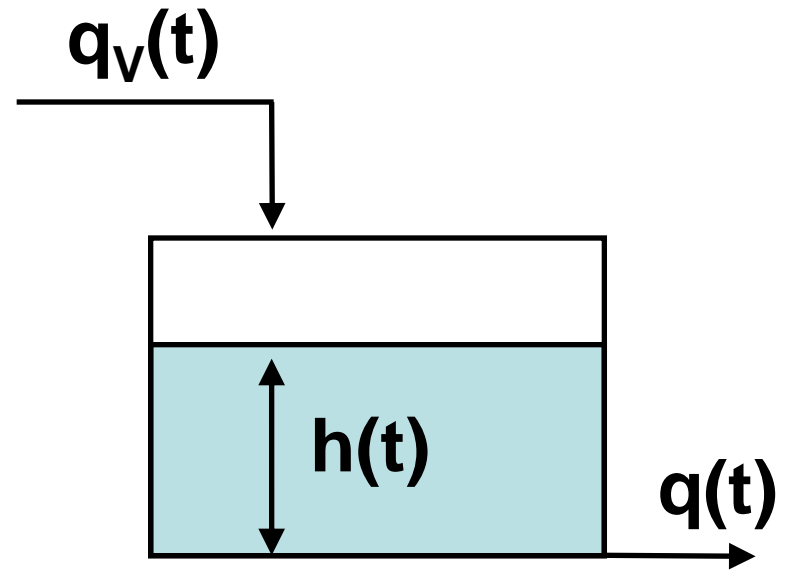

URO

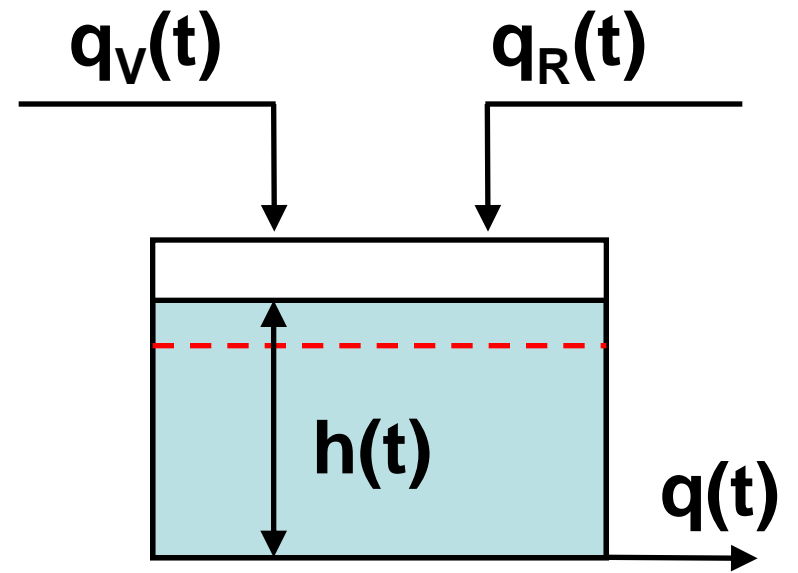

URO

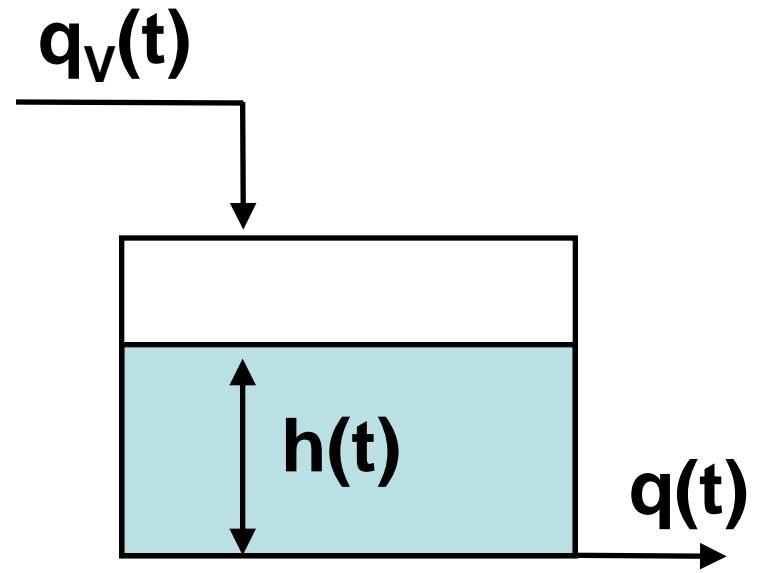

URO

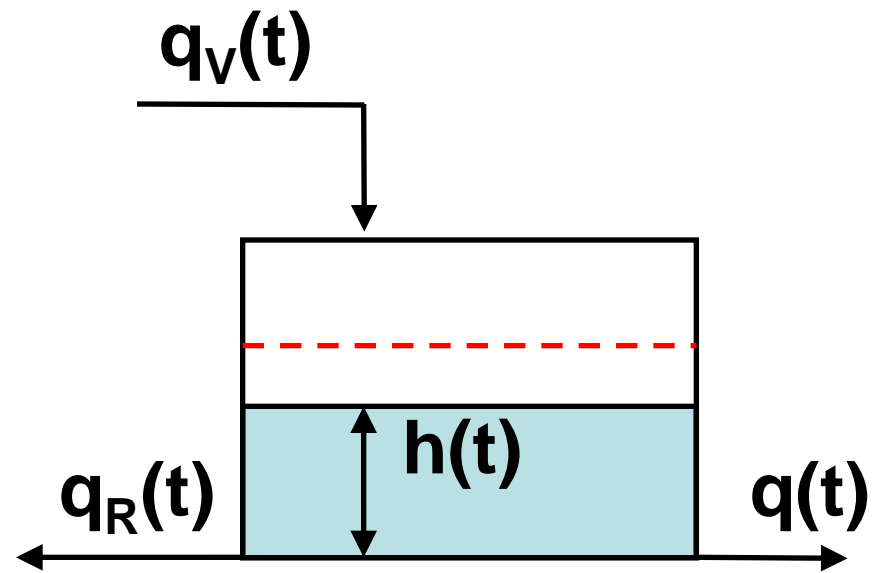

URO

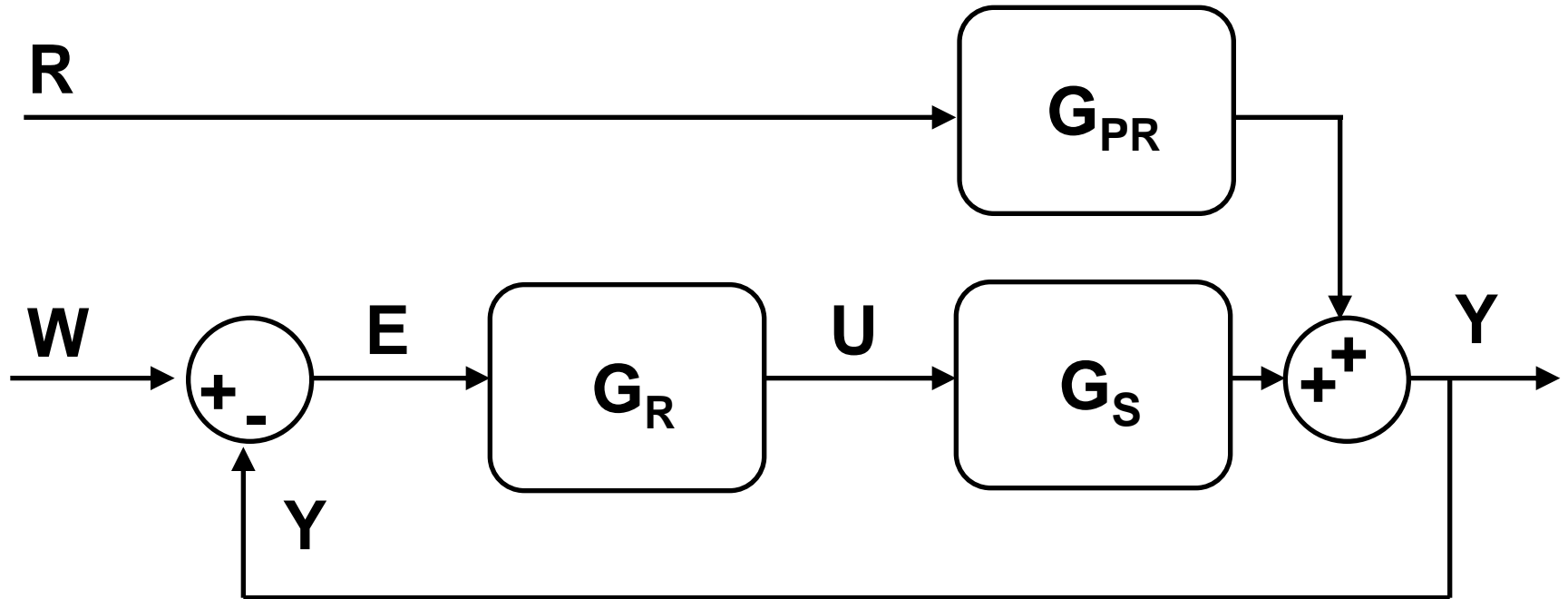

URO

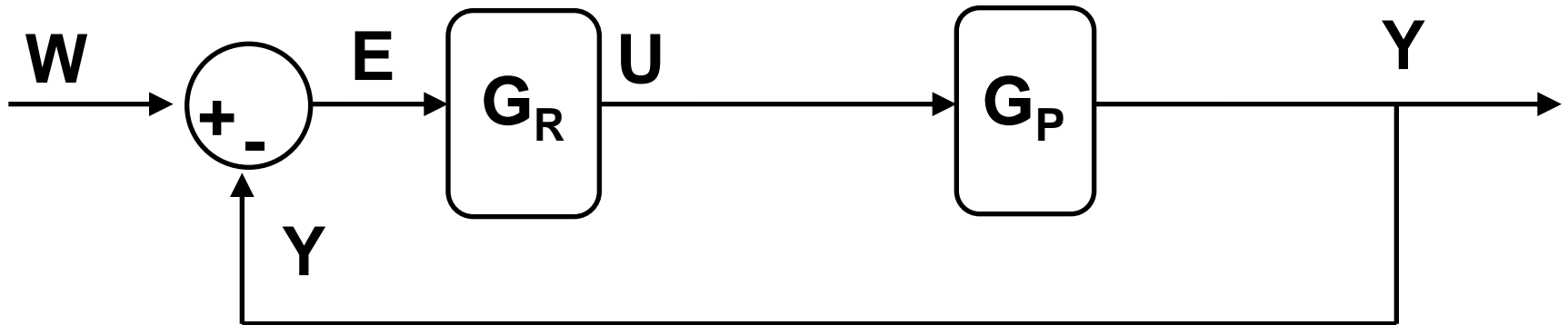

URO

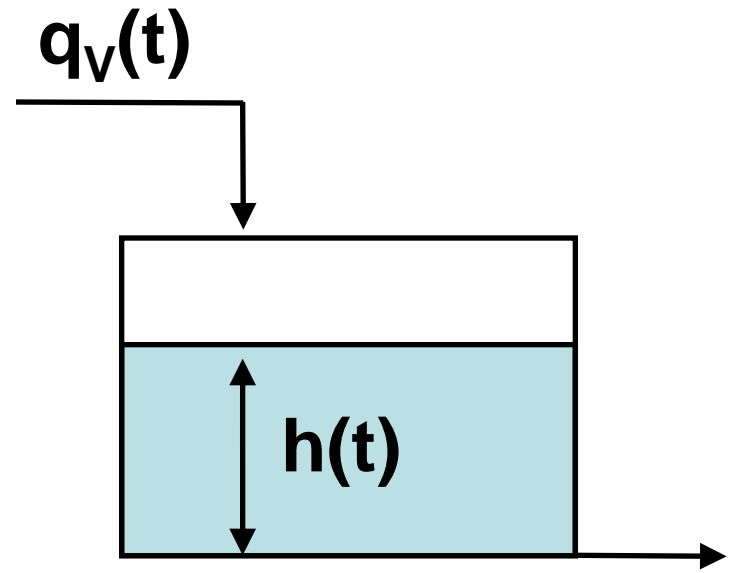

URO

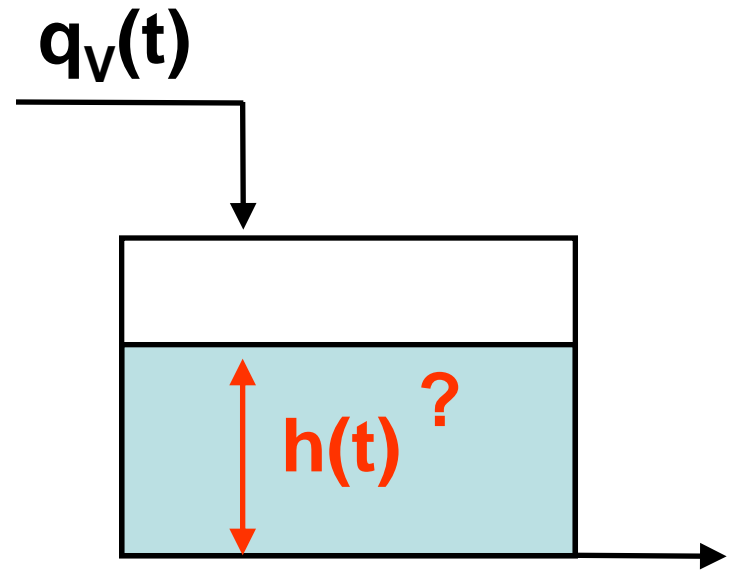

URO

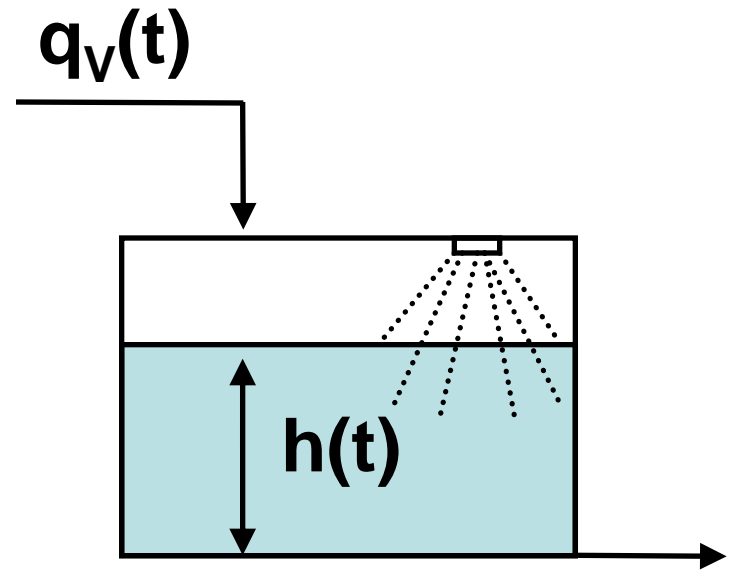

URO

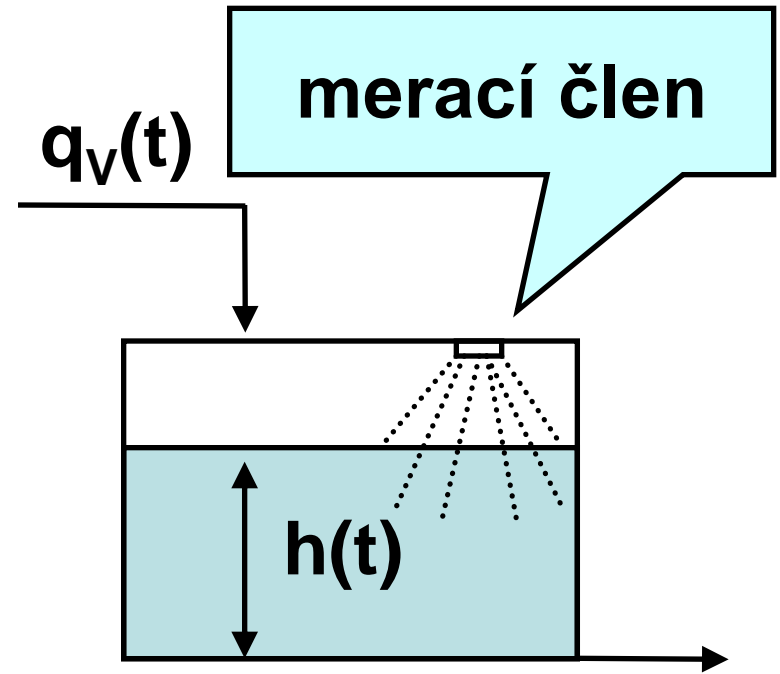

URO

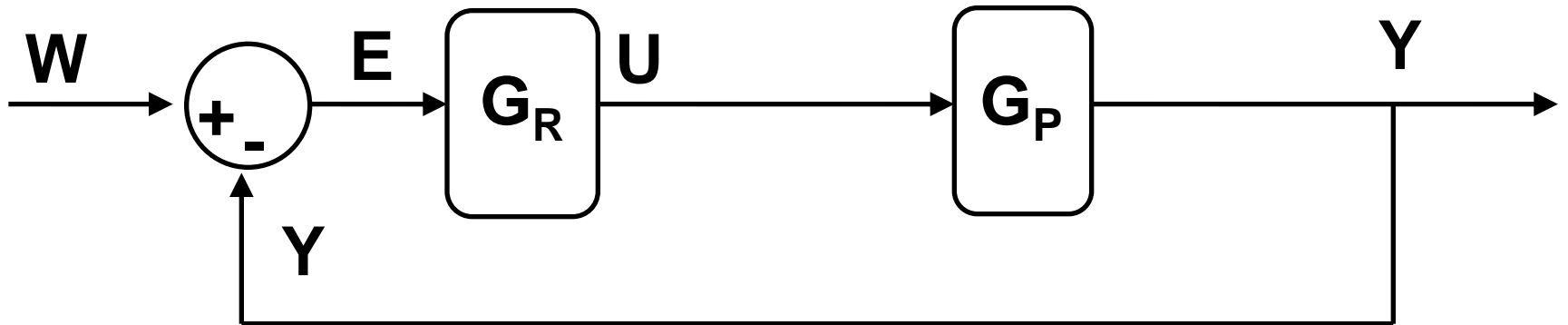

URO

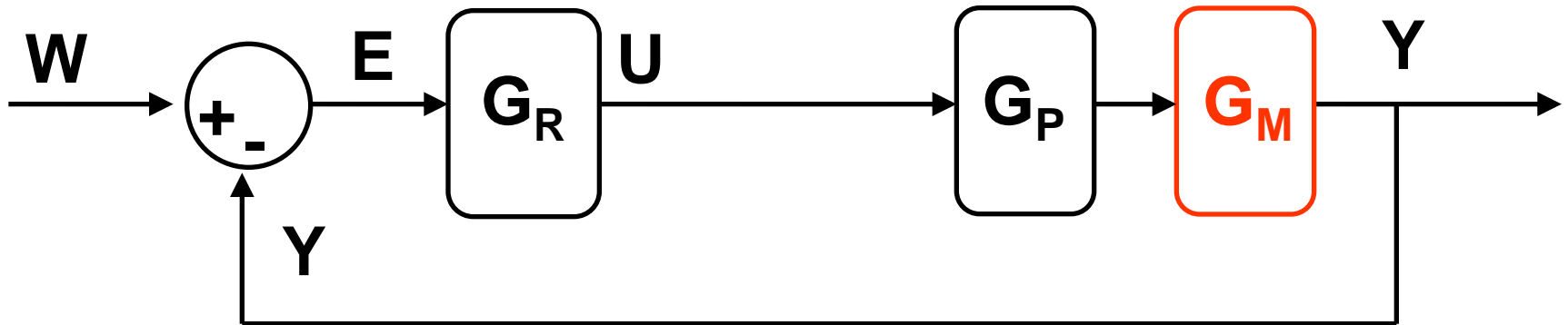

URO

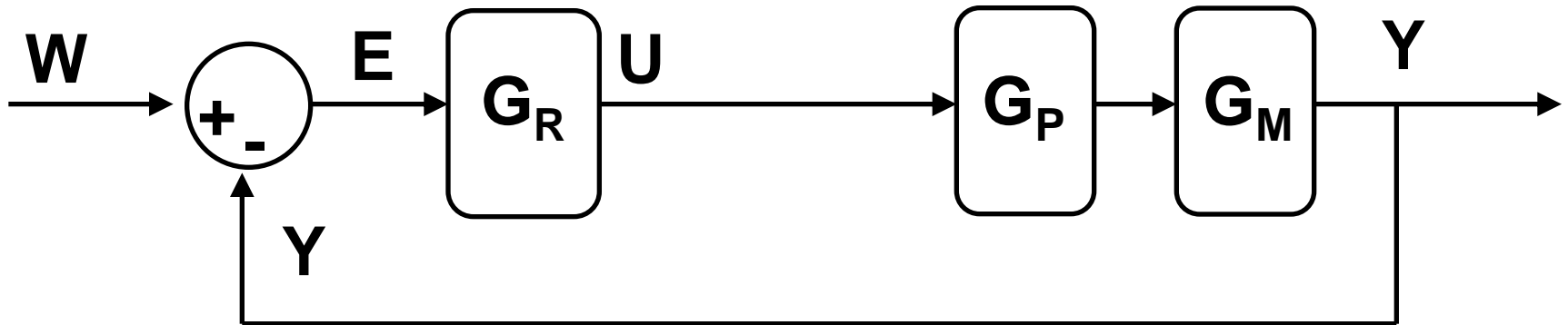

URO

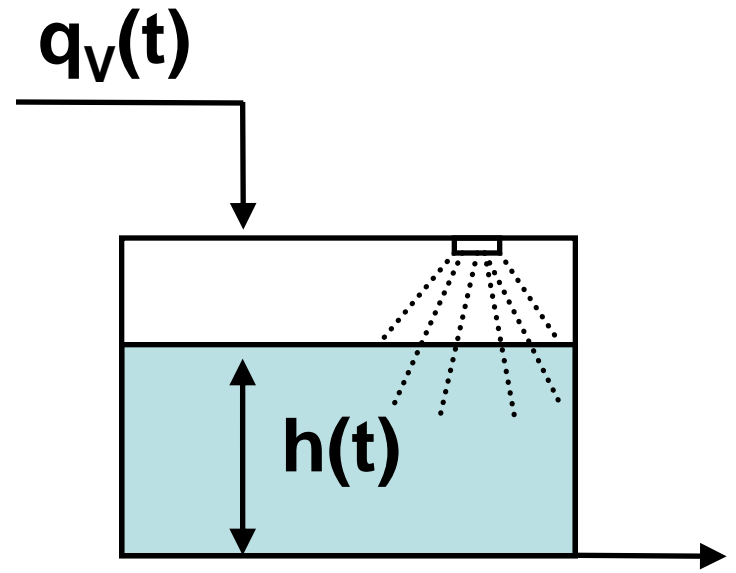

URO

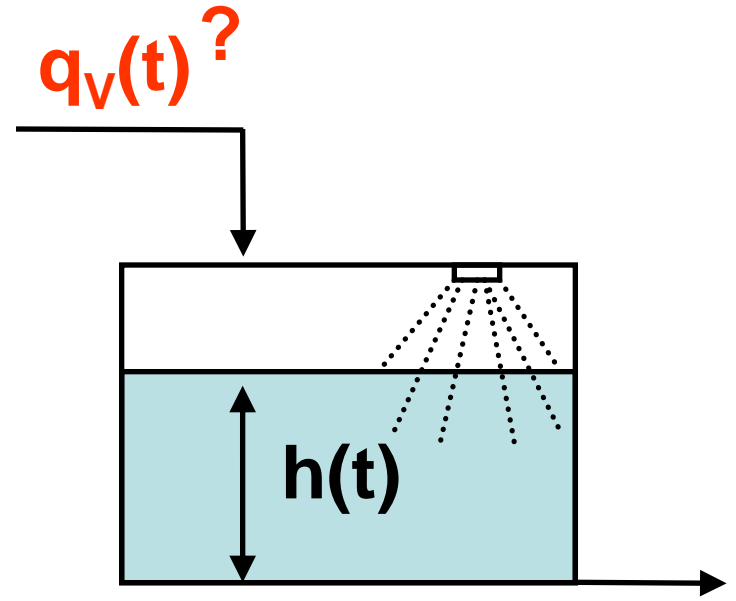

URO

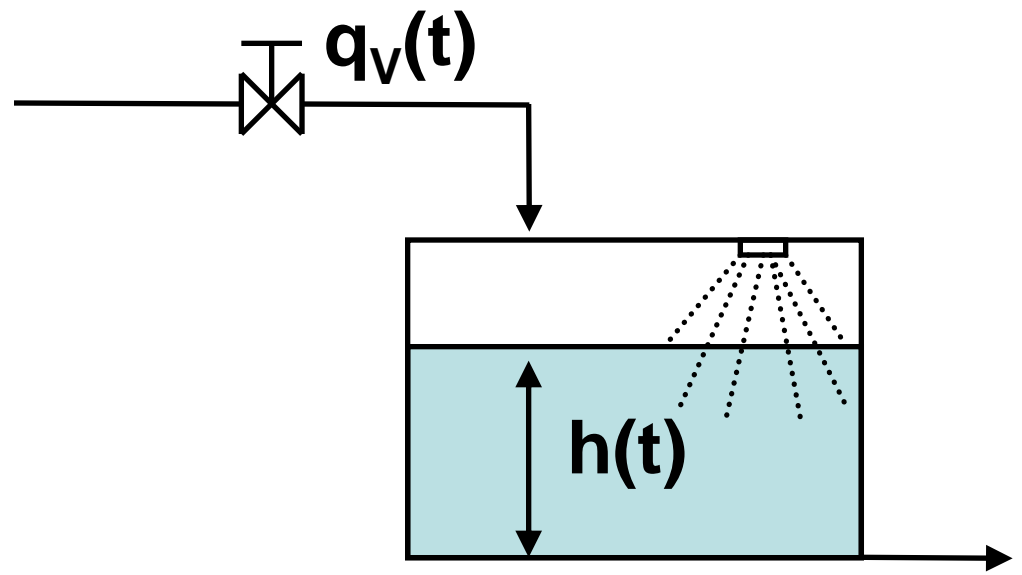

URO

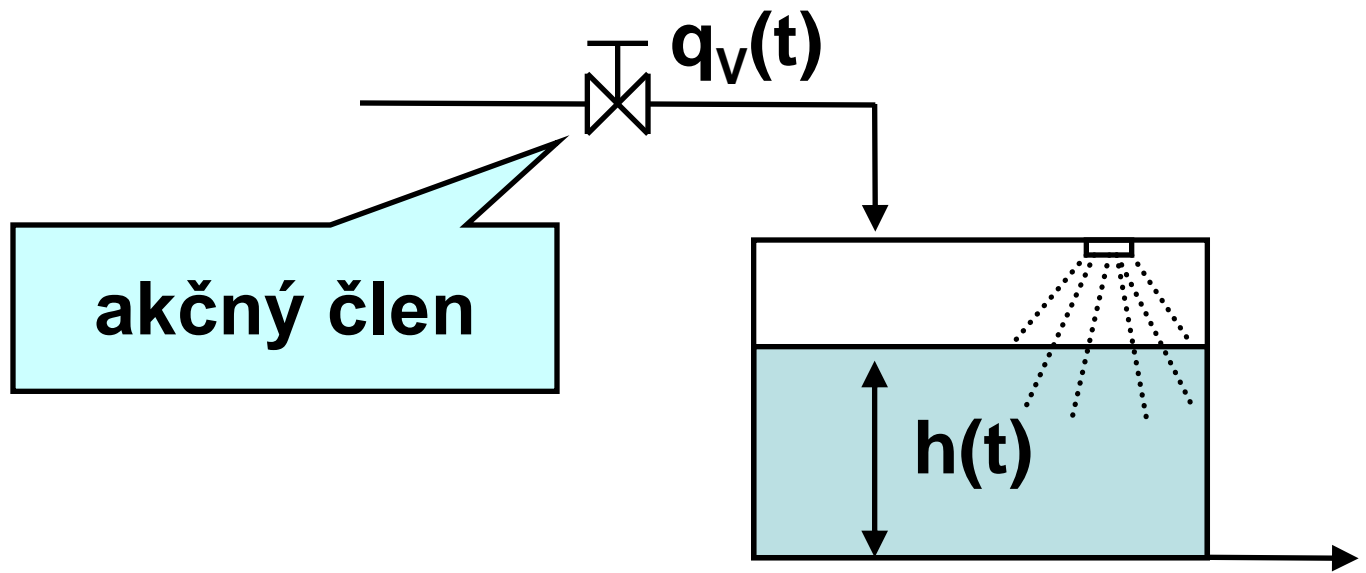

URO

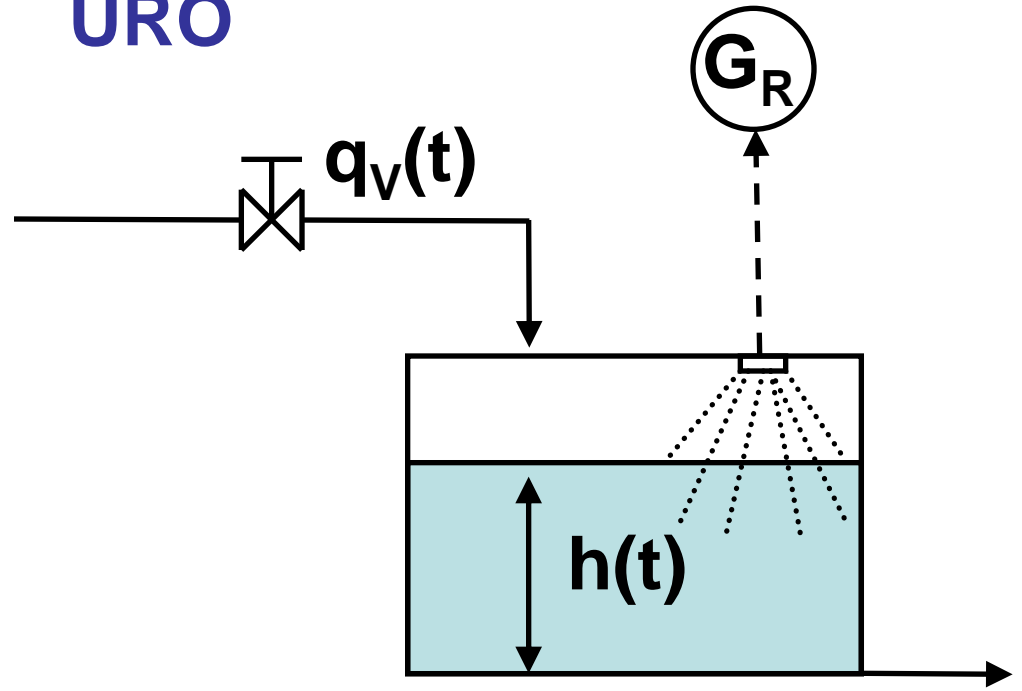

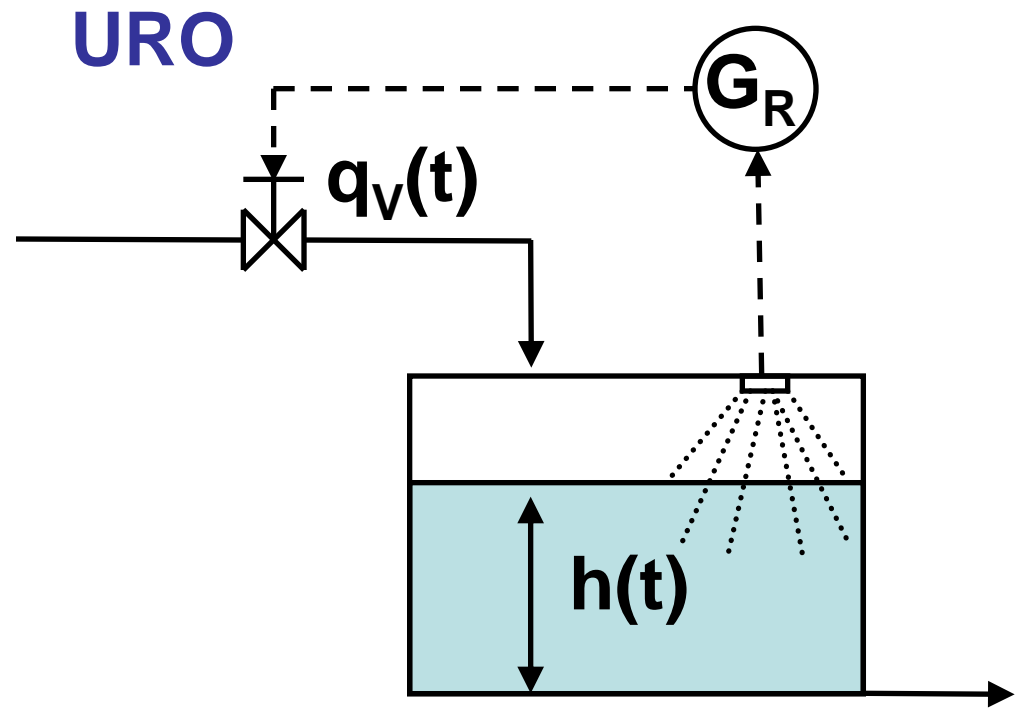

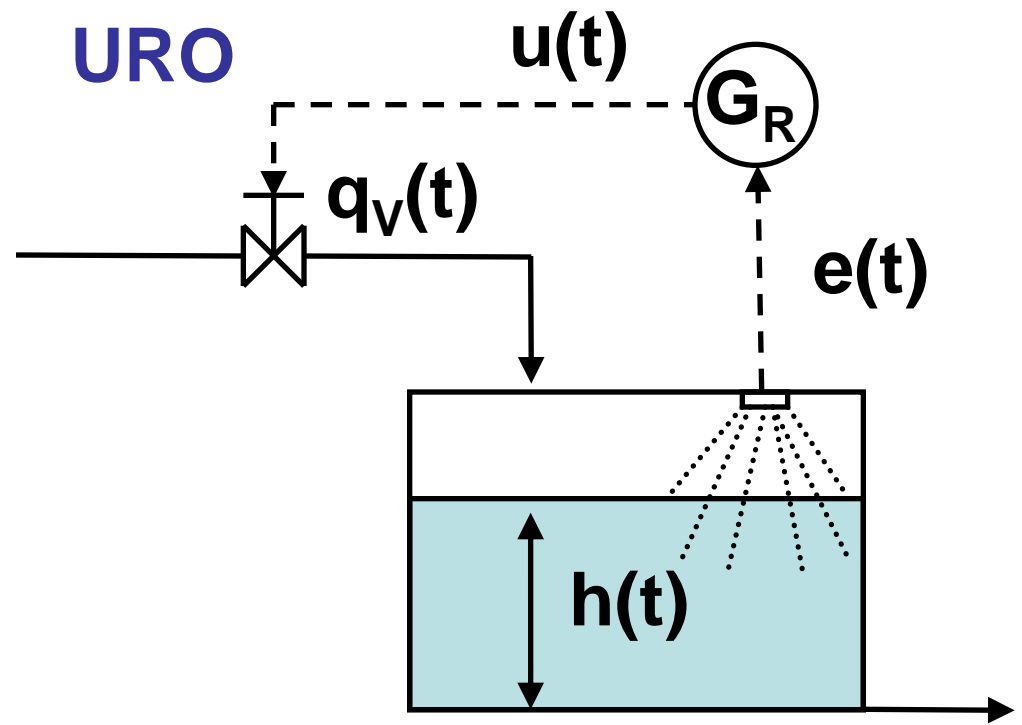

URO

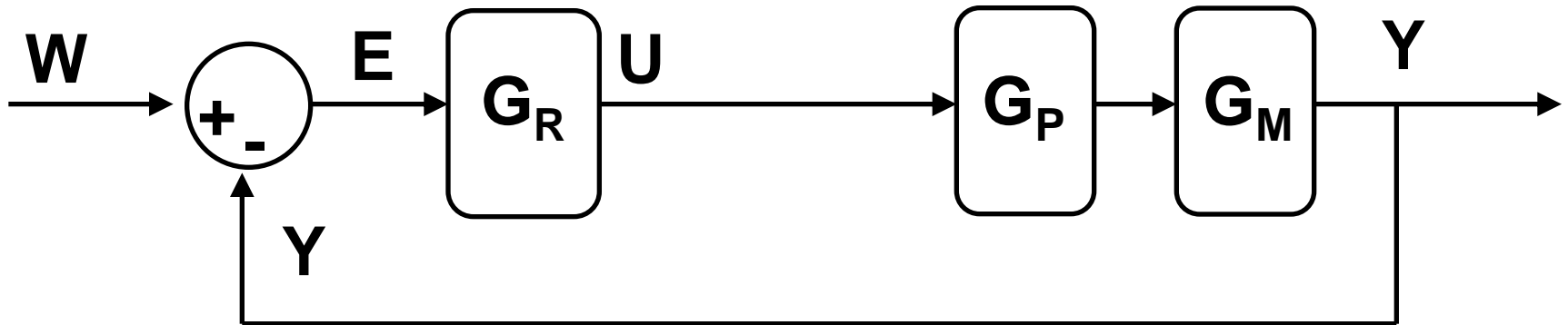

URO

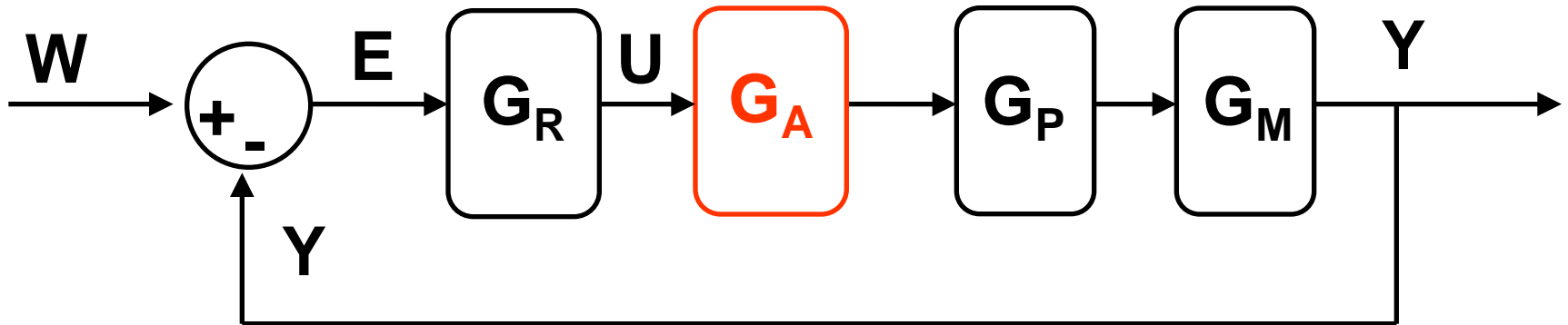

URO

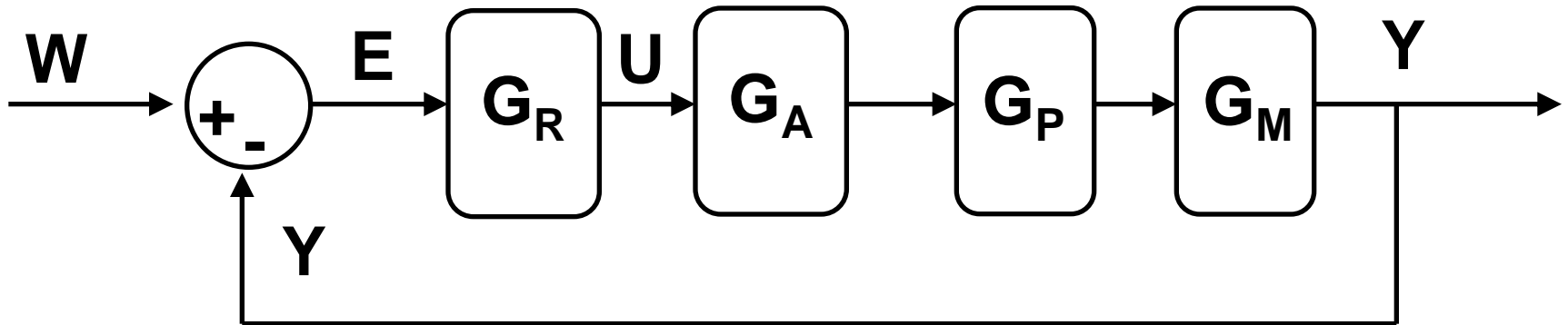

URO

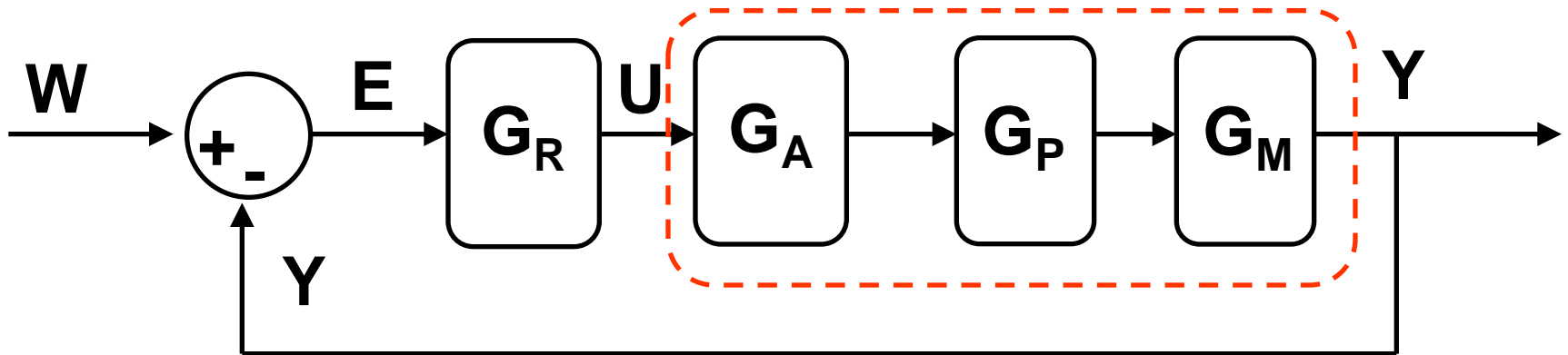

URO

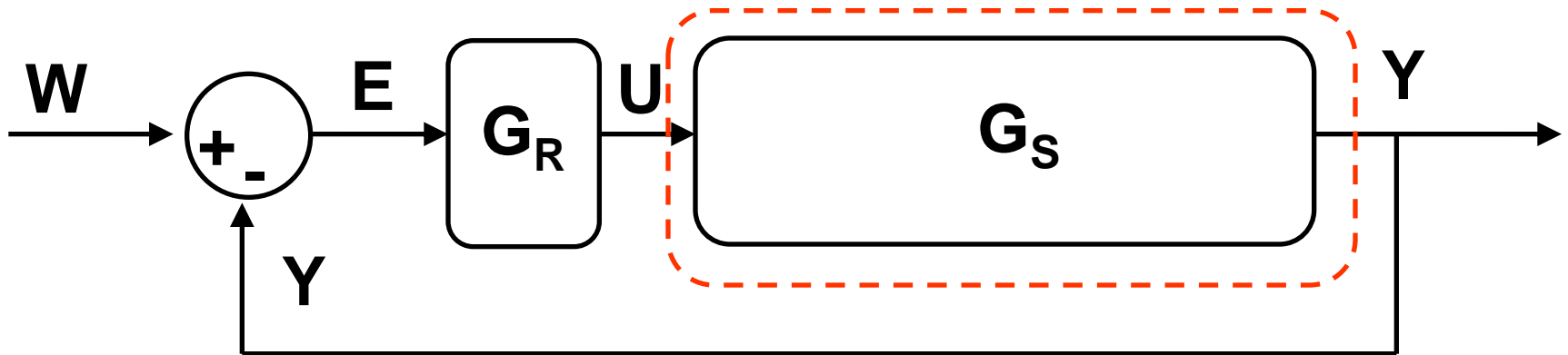

URO

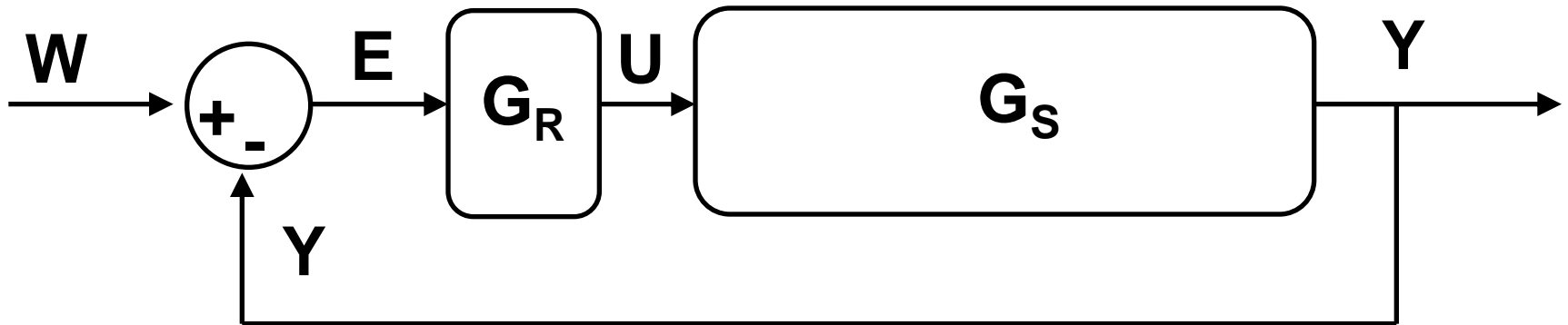

URO

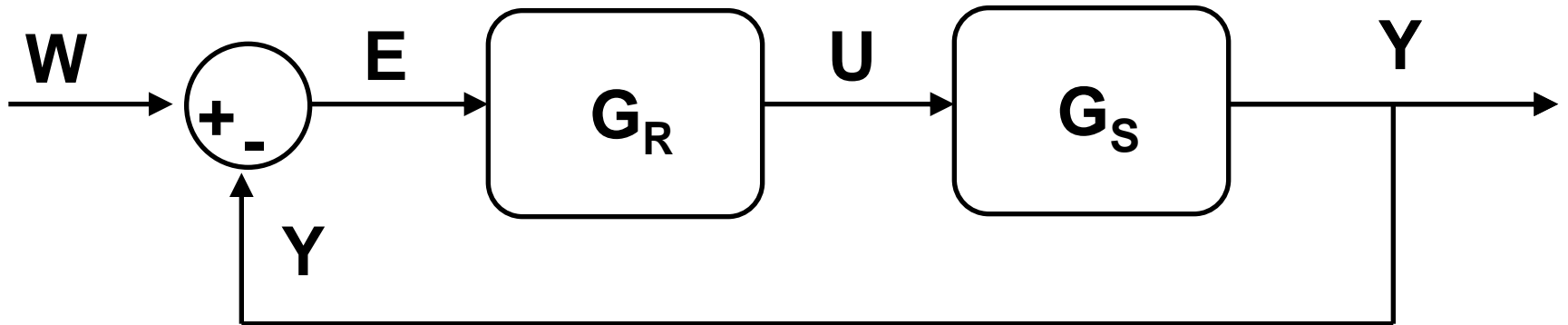

Prenos URO

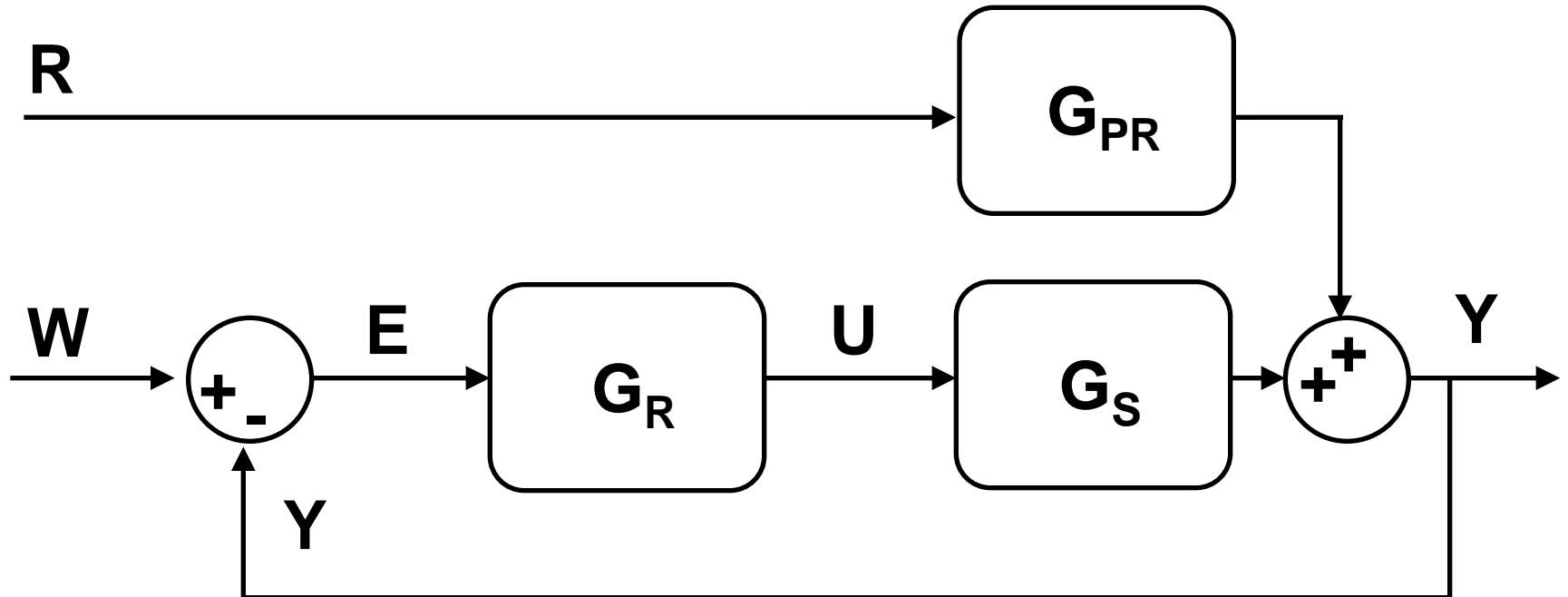

Prenos URO

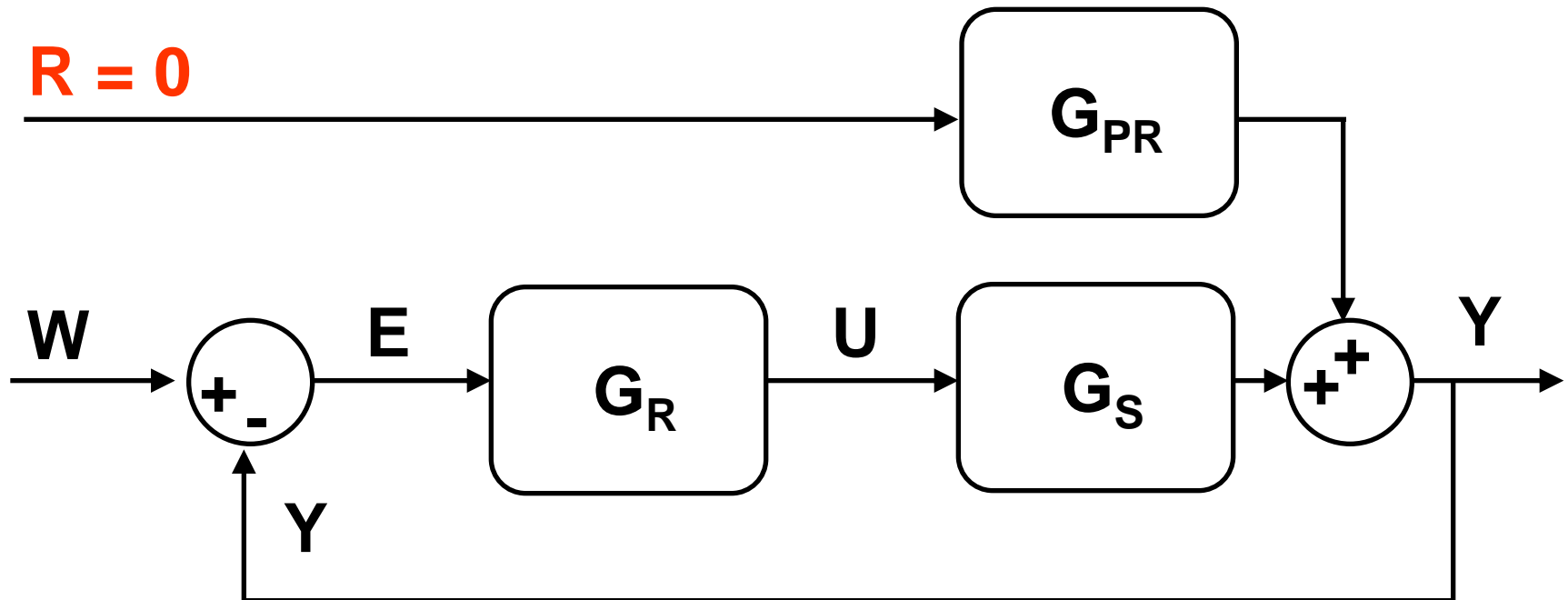

Prenos URO

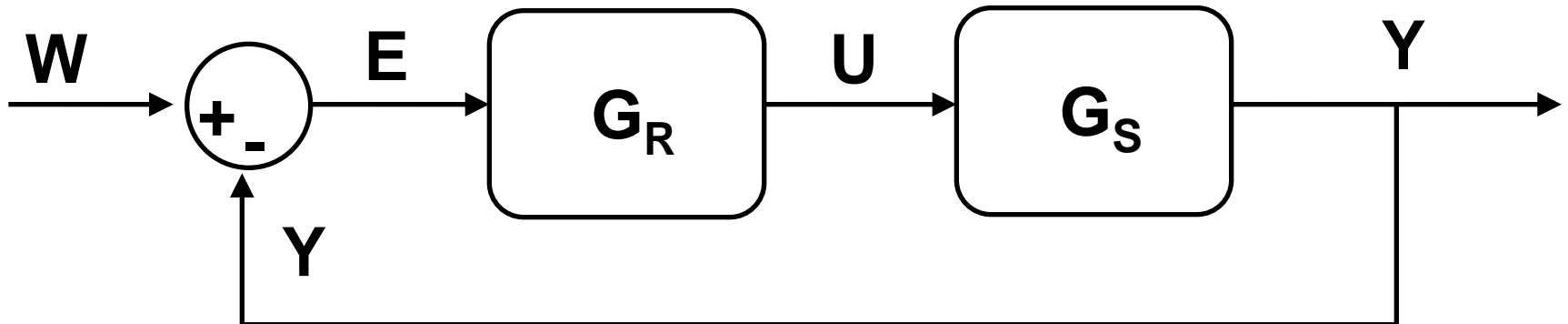

Prenos URO

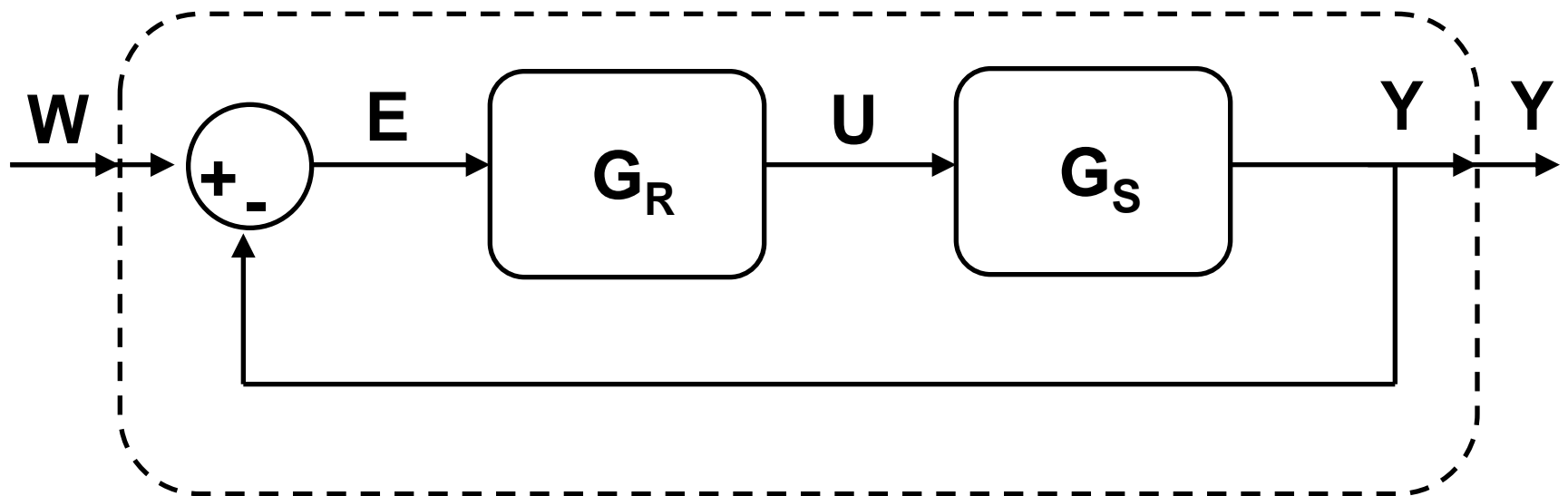

Prenos URO

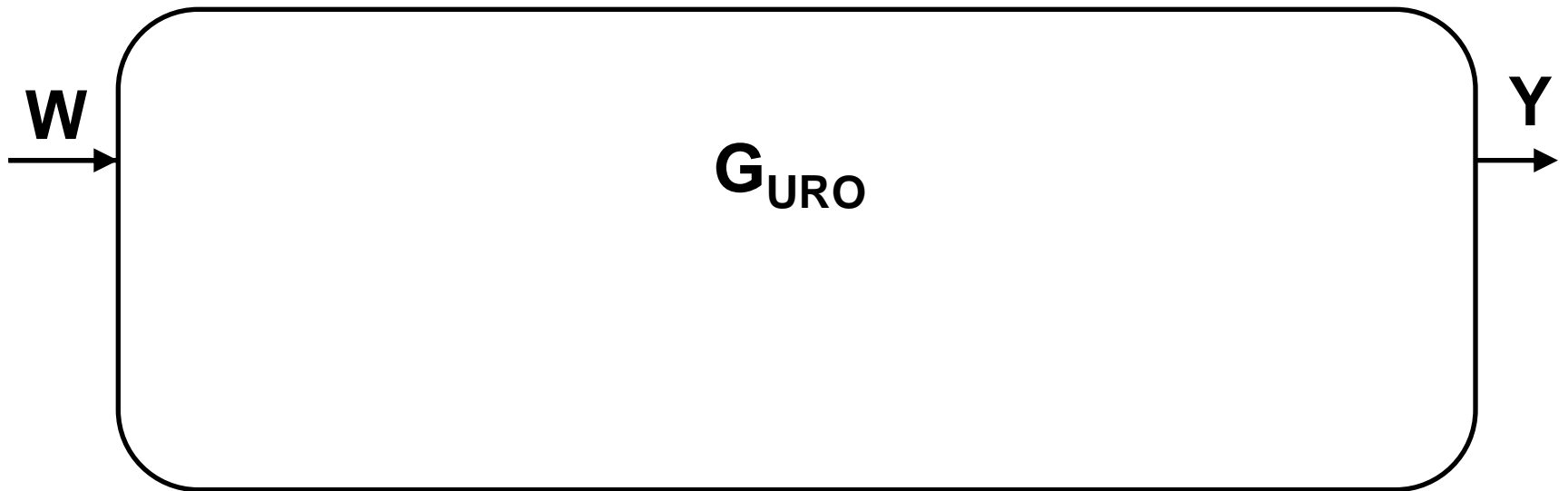

Prenos URO



$$Y = G_{URO}W$$

Prenos URO



$$Y = G_{URO}^? W$$

Prenos URO

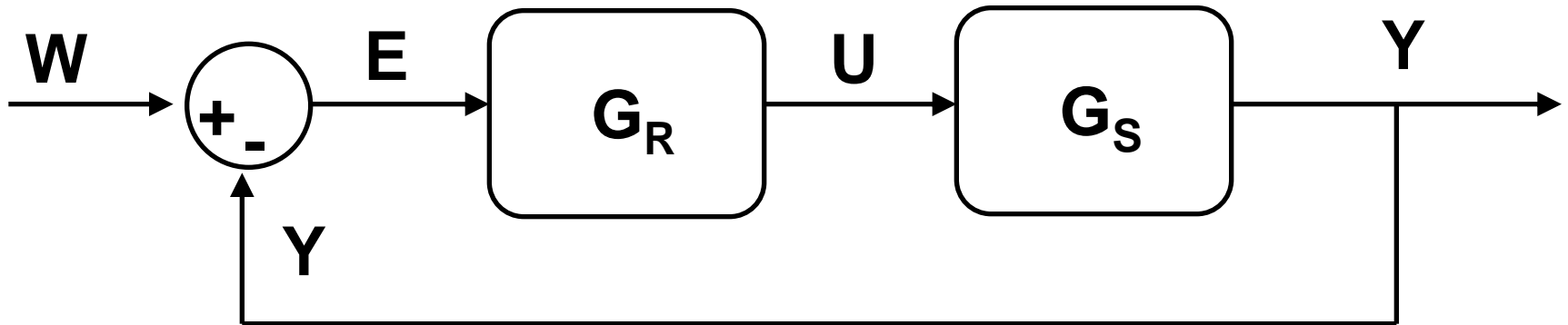

$$Y = G_{URO}^? W$$

Prenos URO

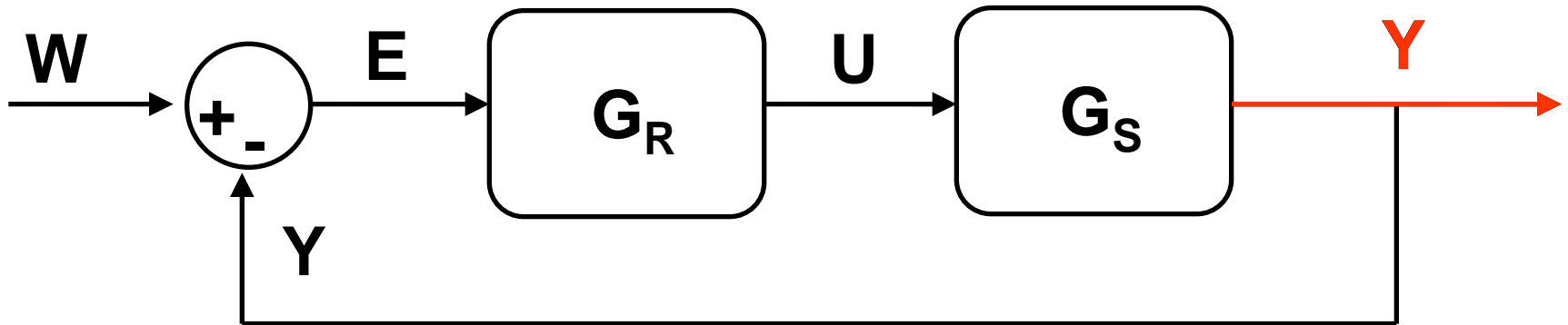

Y

Prenos URO

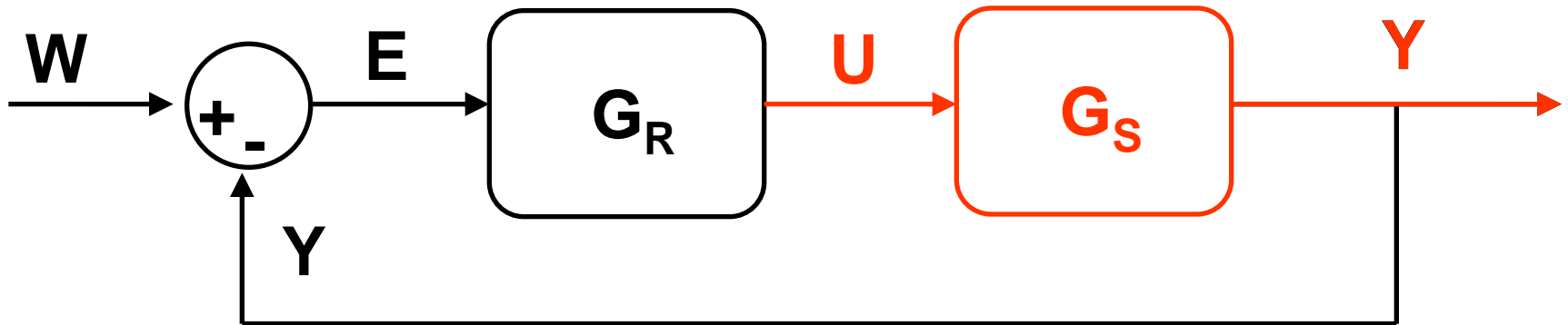

$$Y = G_S U$$

Prenos URO

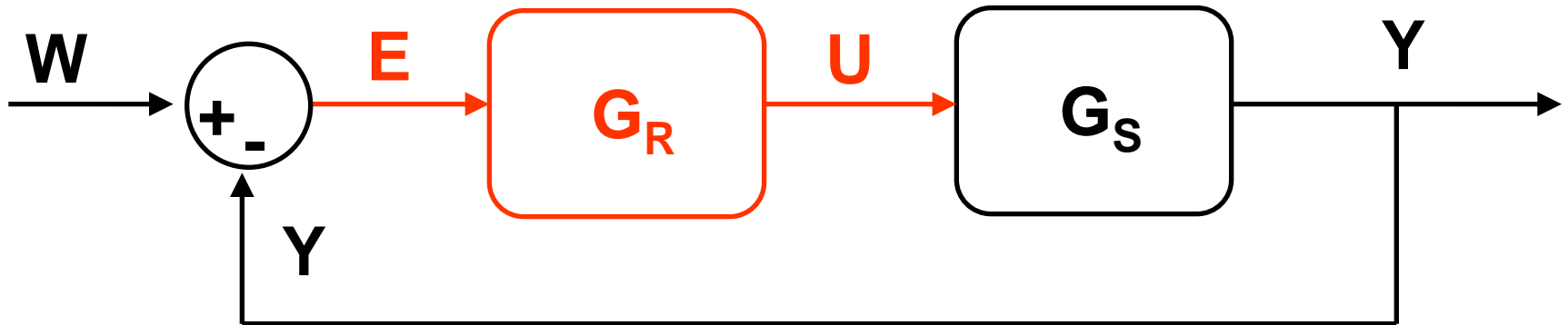

$$Y = G_S U = G_S G_R E$$

Prenos URO

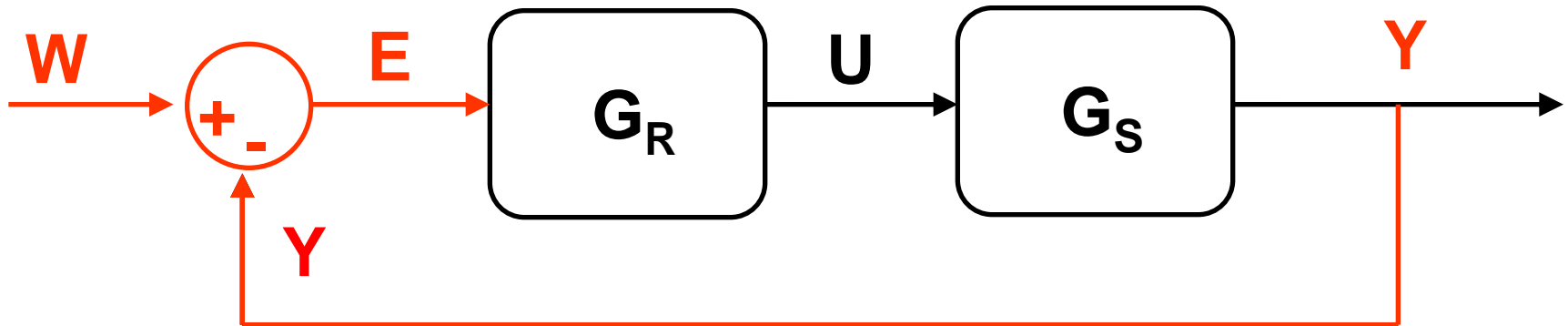

$$Y = G_S U = G_S G_R E = G_S G_R (W - Y)$$

Prenos URO

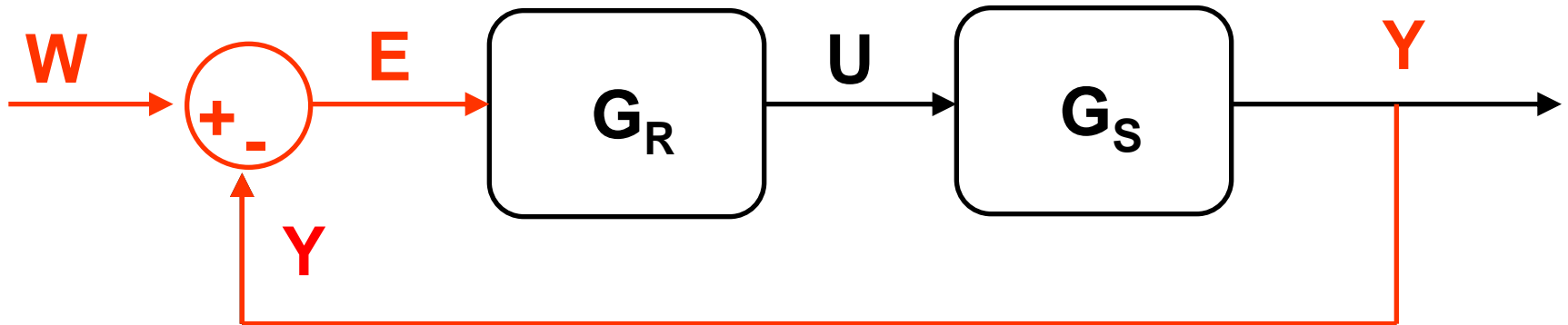

$$\begin{aligned} Y &= G_S U = G_S G_R E = G_S G_R (W - Y) = \\ &= G_S G_R W - G_S G_R Y \end{aligned}$$

Prenos URO

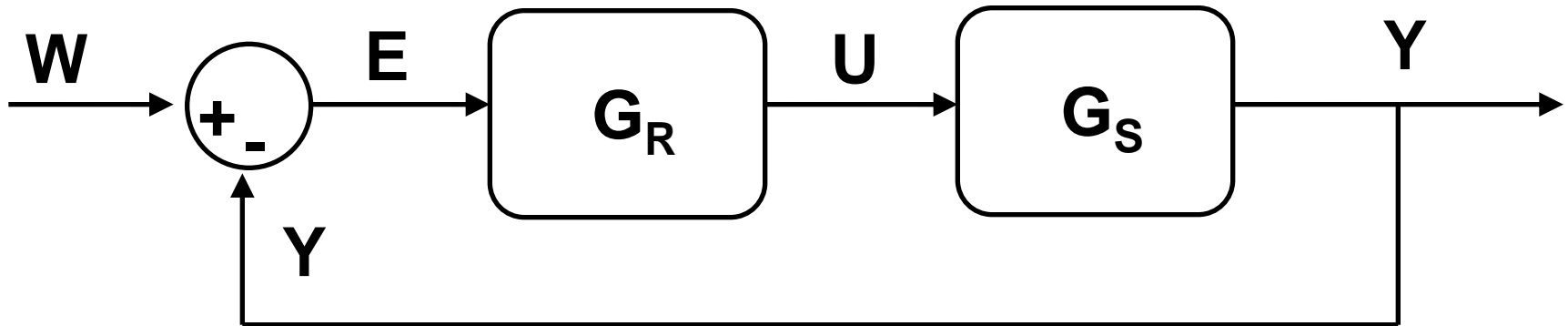

$$Y = G_S G_R W - G_S G_R Y$$

Prenos URO

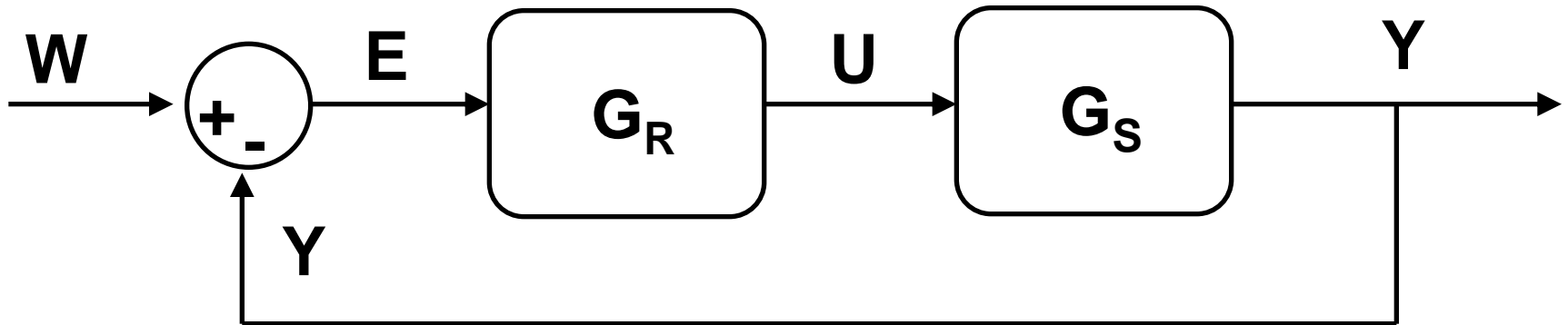

$$Y = \frac{G_S G_R W - G_S G_R Y}{1 + G_S G_R Y}$$

Prenos URO

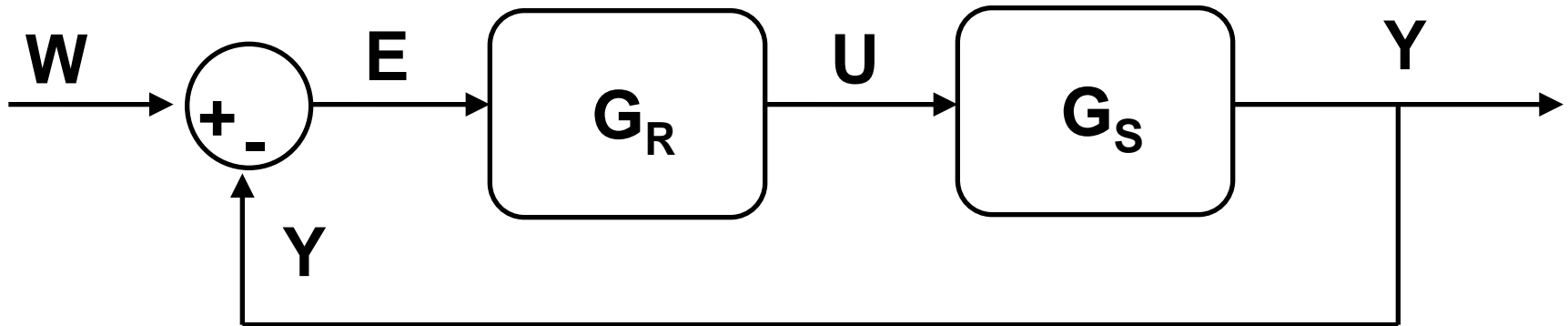

$$Y + G_S G_R Y = G_S G_R W$$

Prenos URO

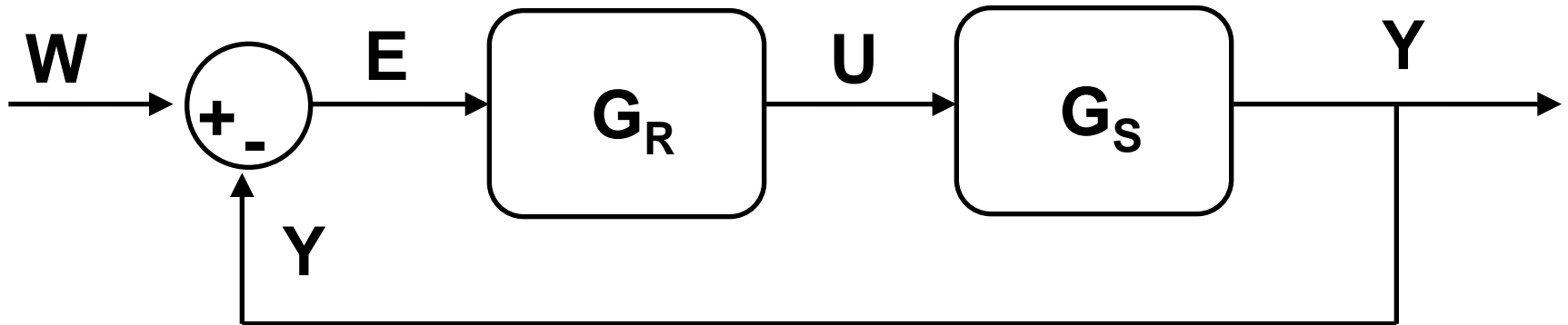

$$Y(1 + G_S G_R) = G_S G_R W$$

Prenos URO

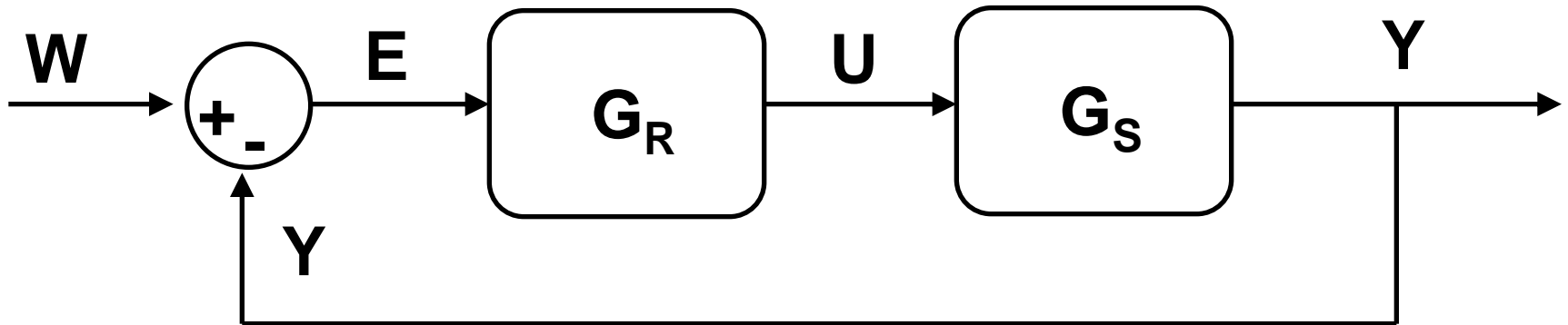

$$Y / W = G_S G_R / (1 + G_S G_R)$$

Prenos URO

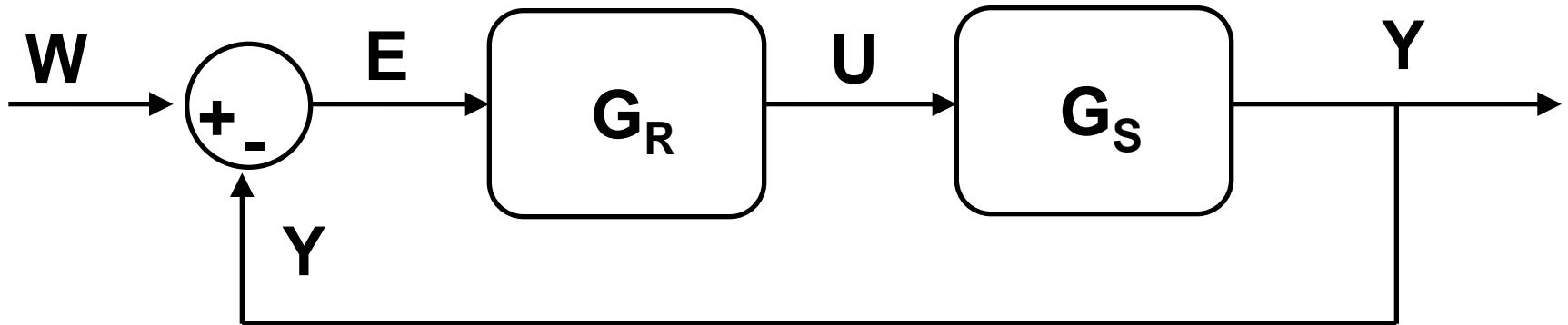

$$G_{URO} = \frac{Y}{W} = \frac{G_R G_S}{1 + G_R G_S}$$

Prenos URO

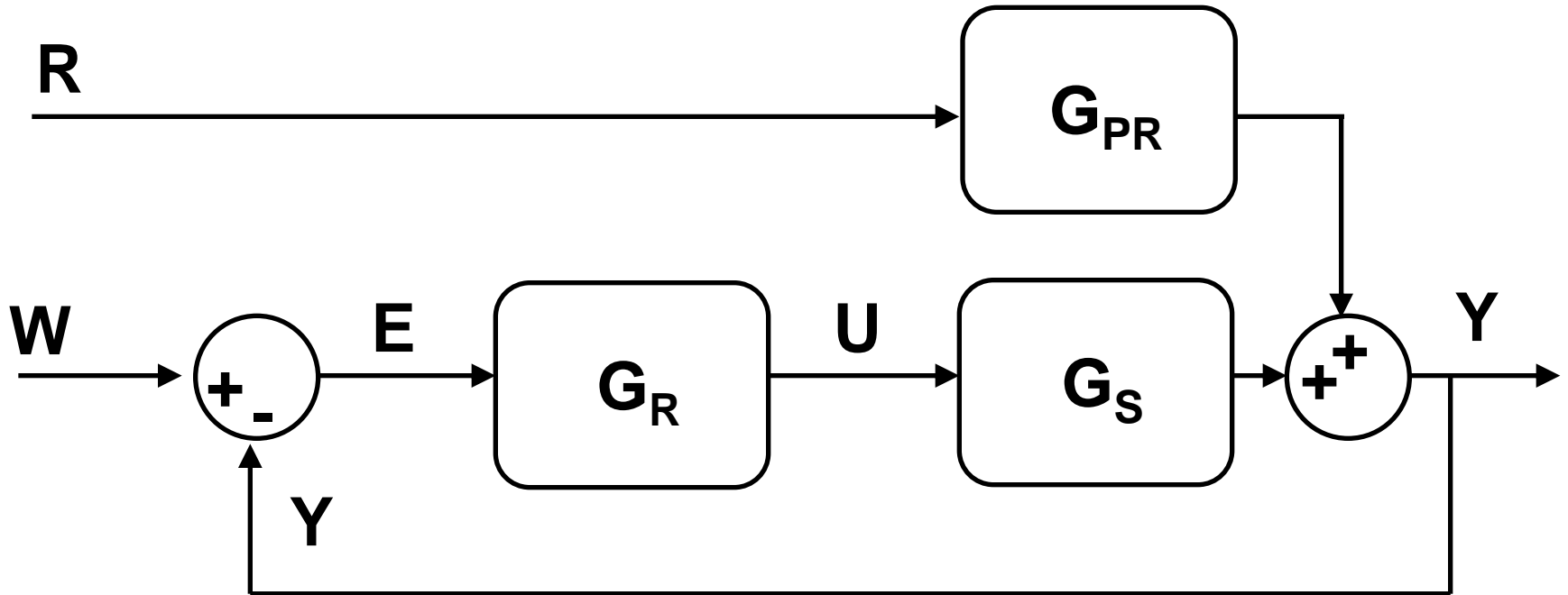

Prenos URO

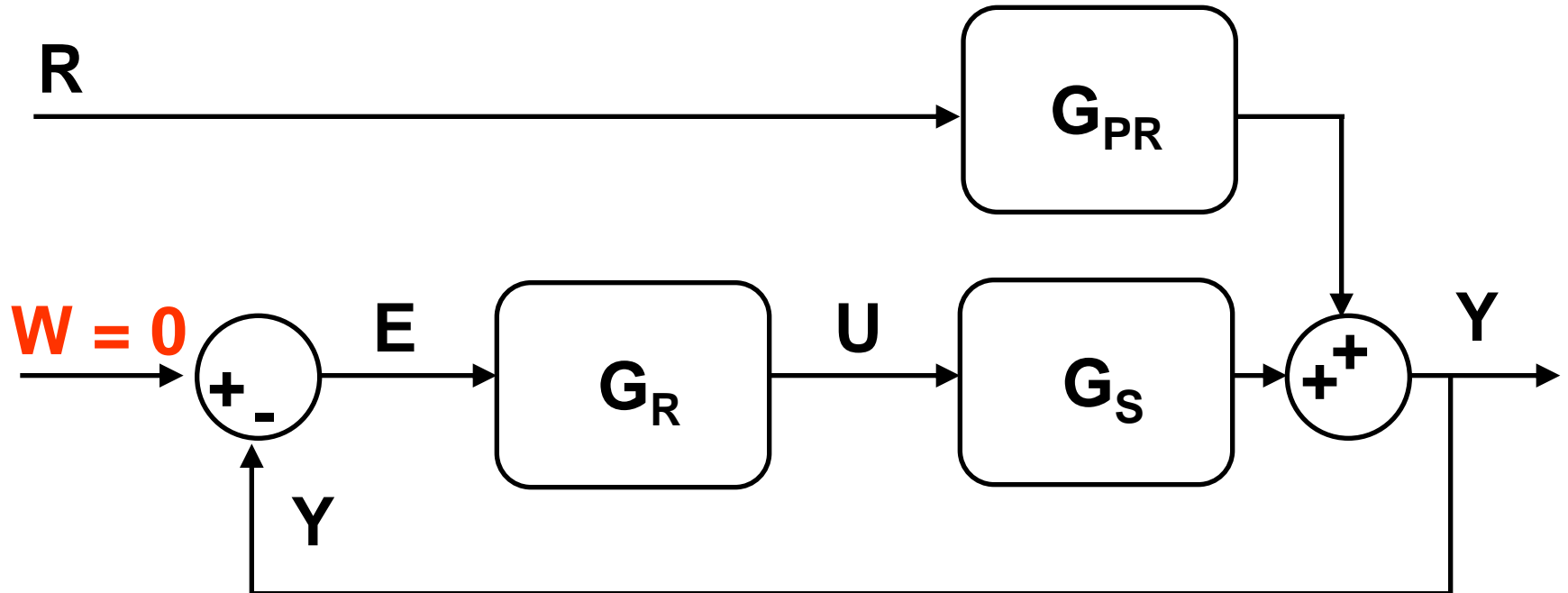

Prenos URO

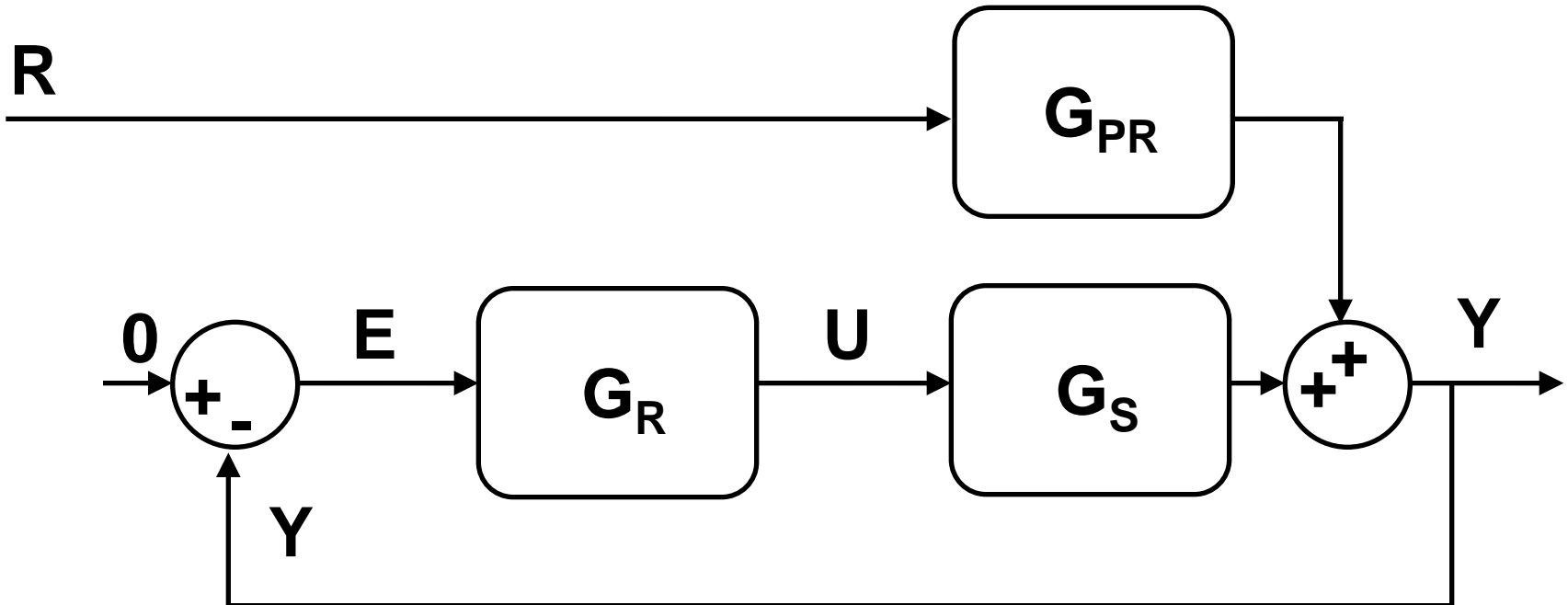

Prenos URO

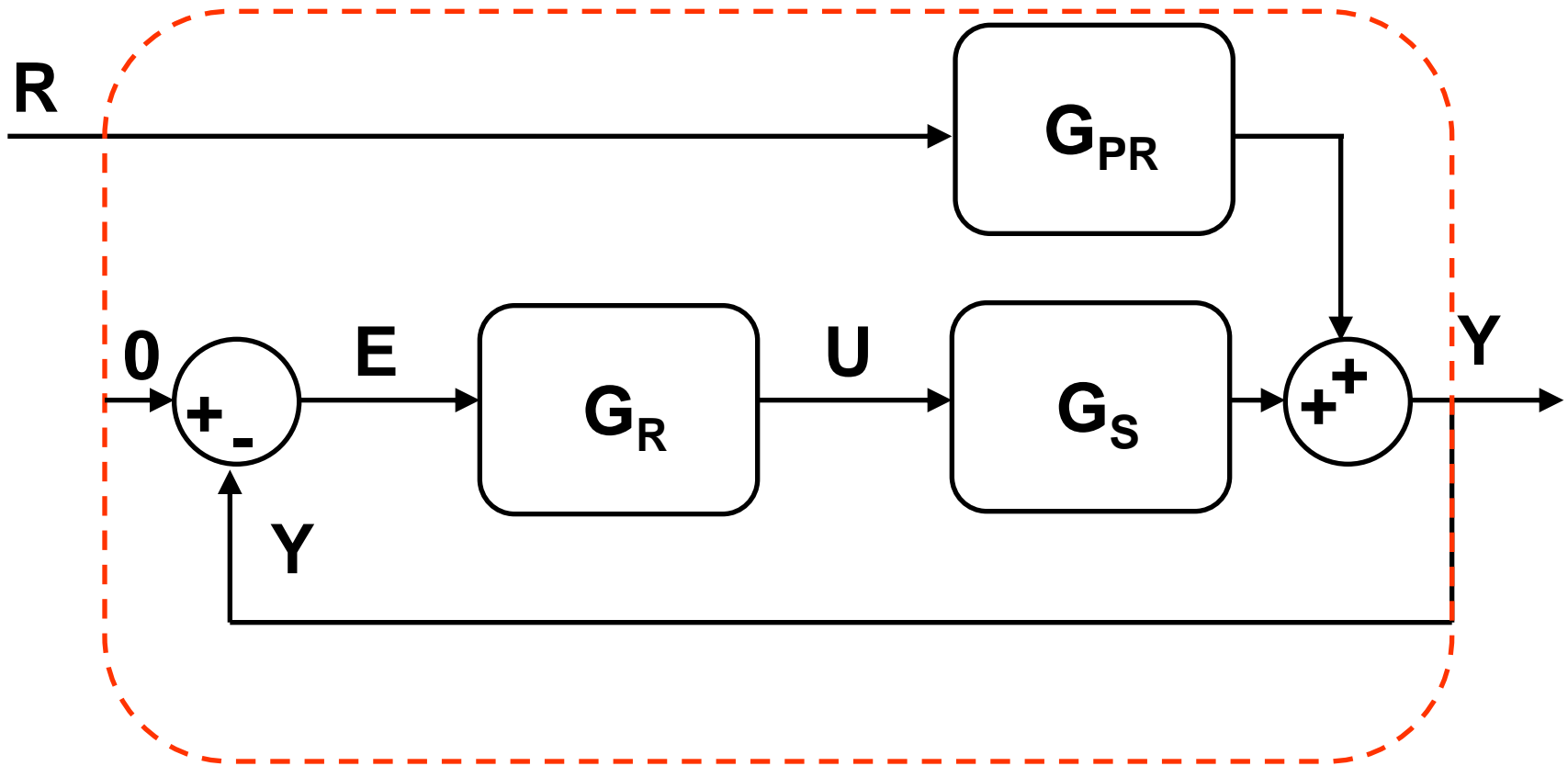

Prenos URO

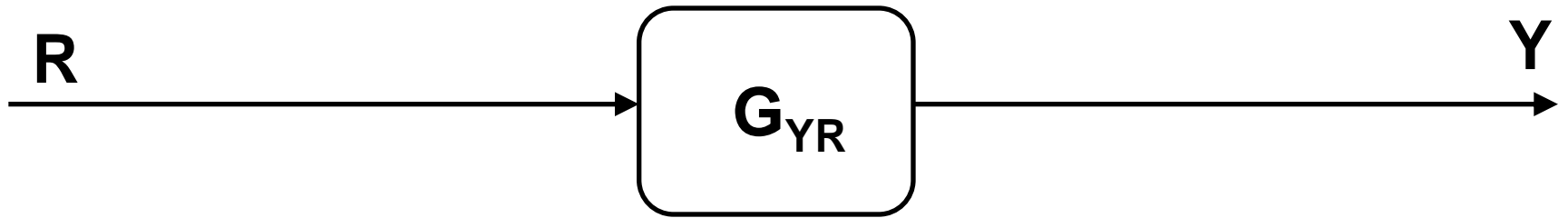

$$Y = G_{YR}R$$

Prenos URO

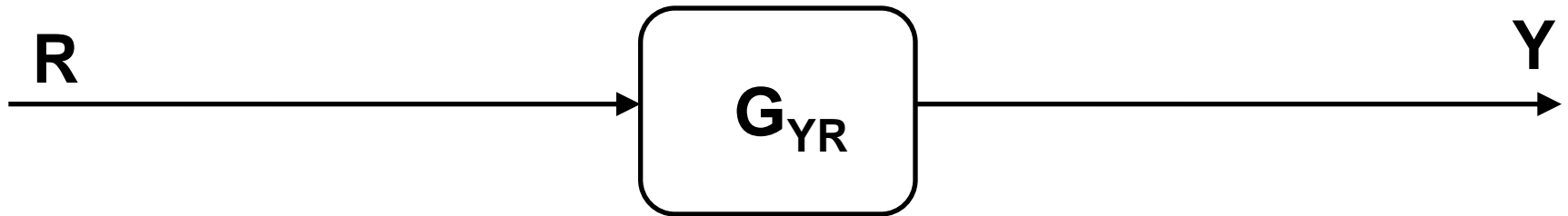

$$Y = G_{YR}^? R$$

Prenos URO

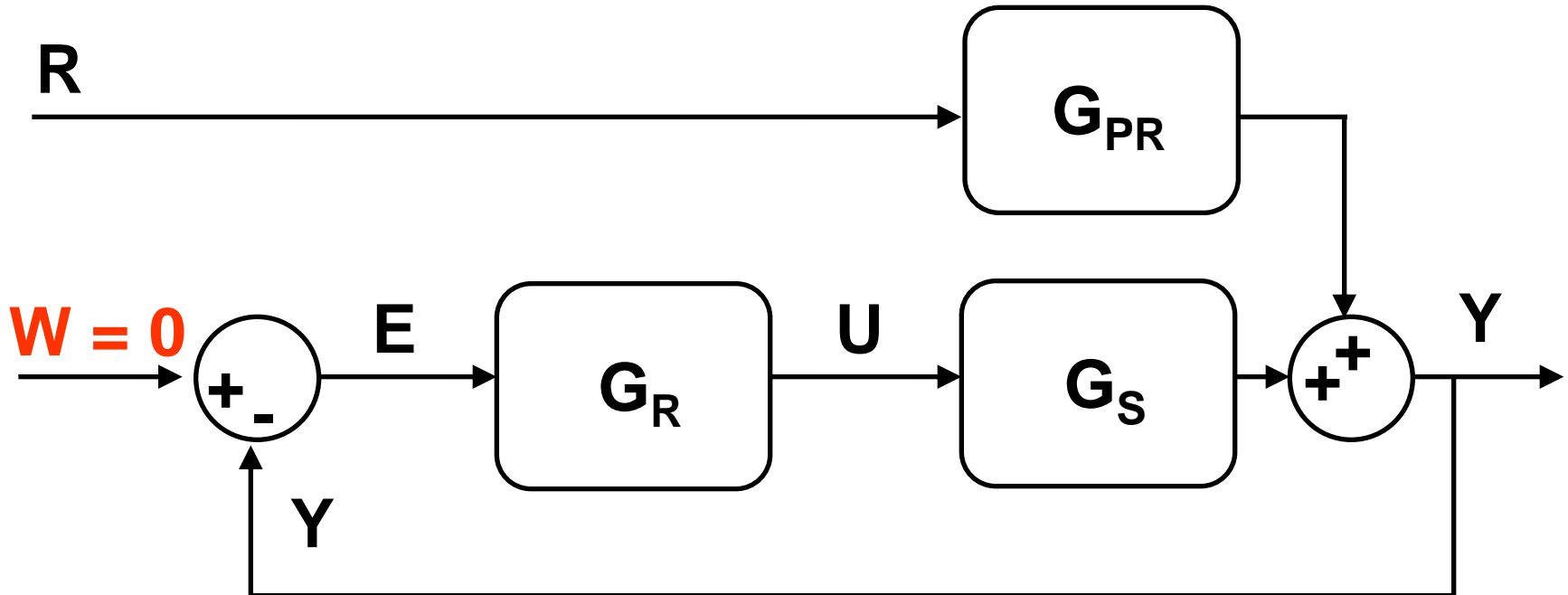

Prenos URO

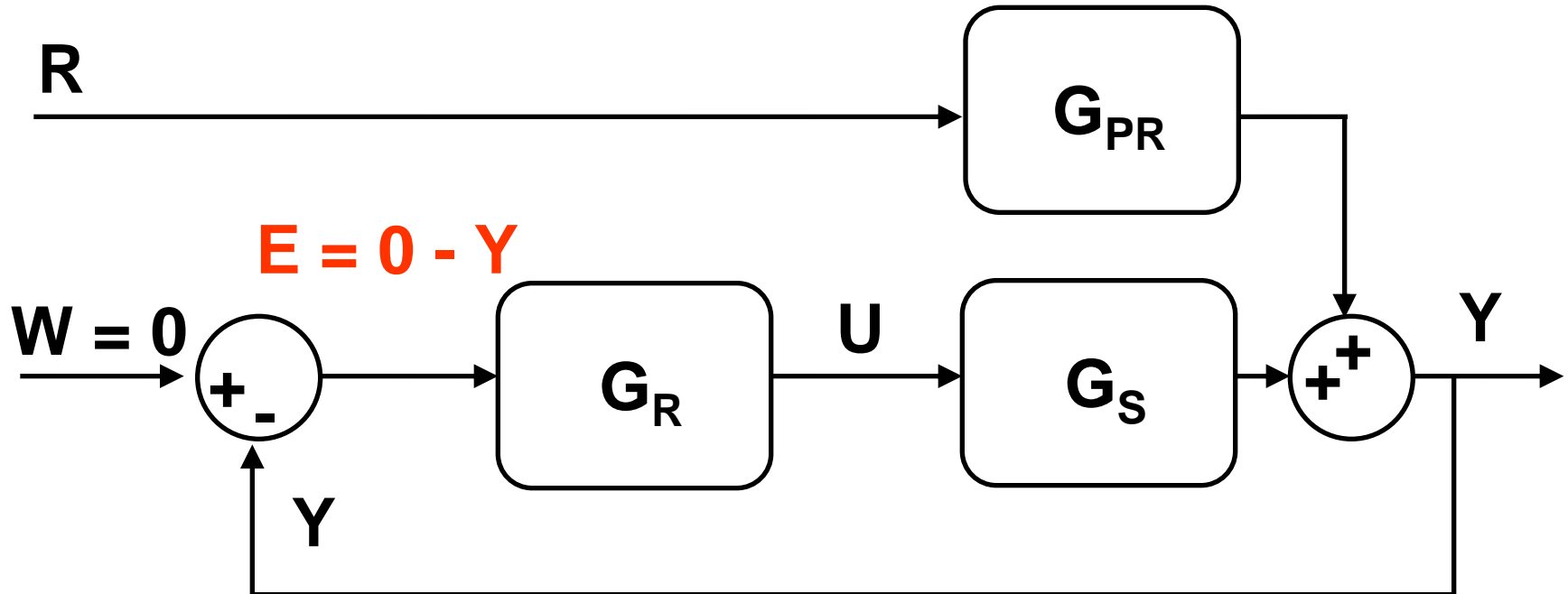

Prenos URO

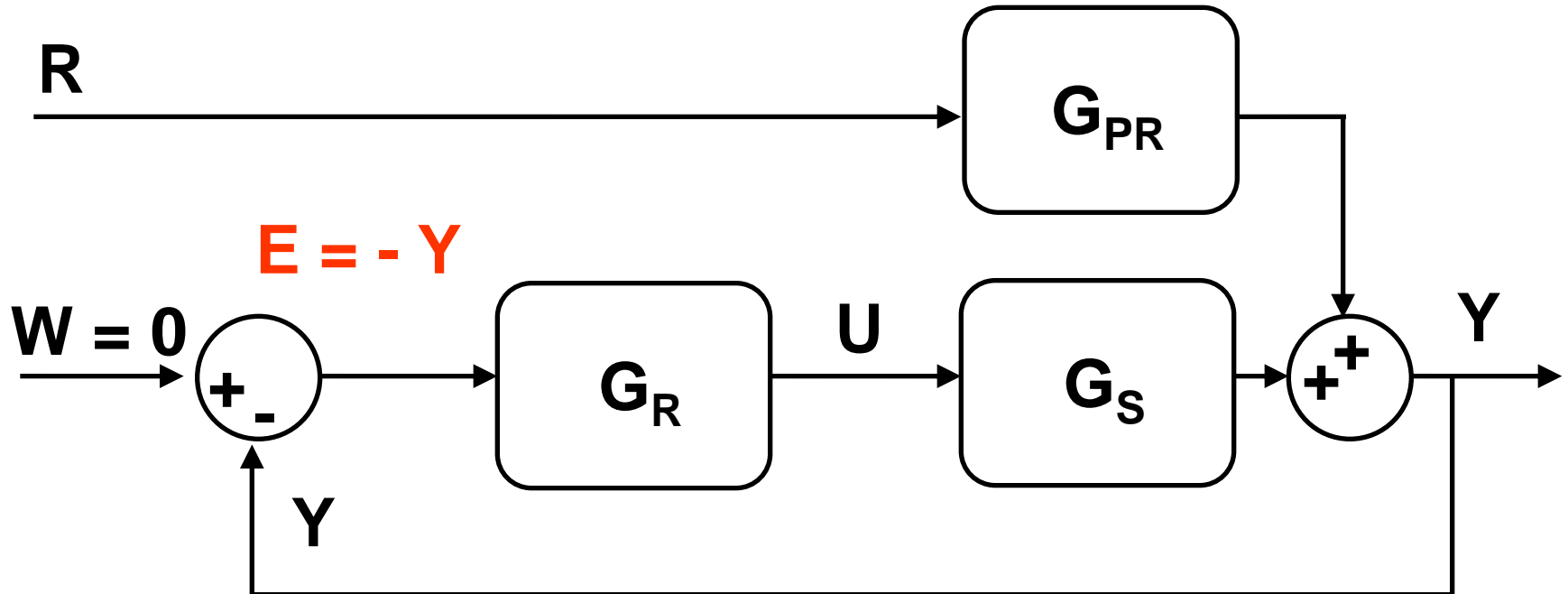

Prenos URO

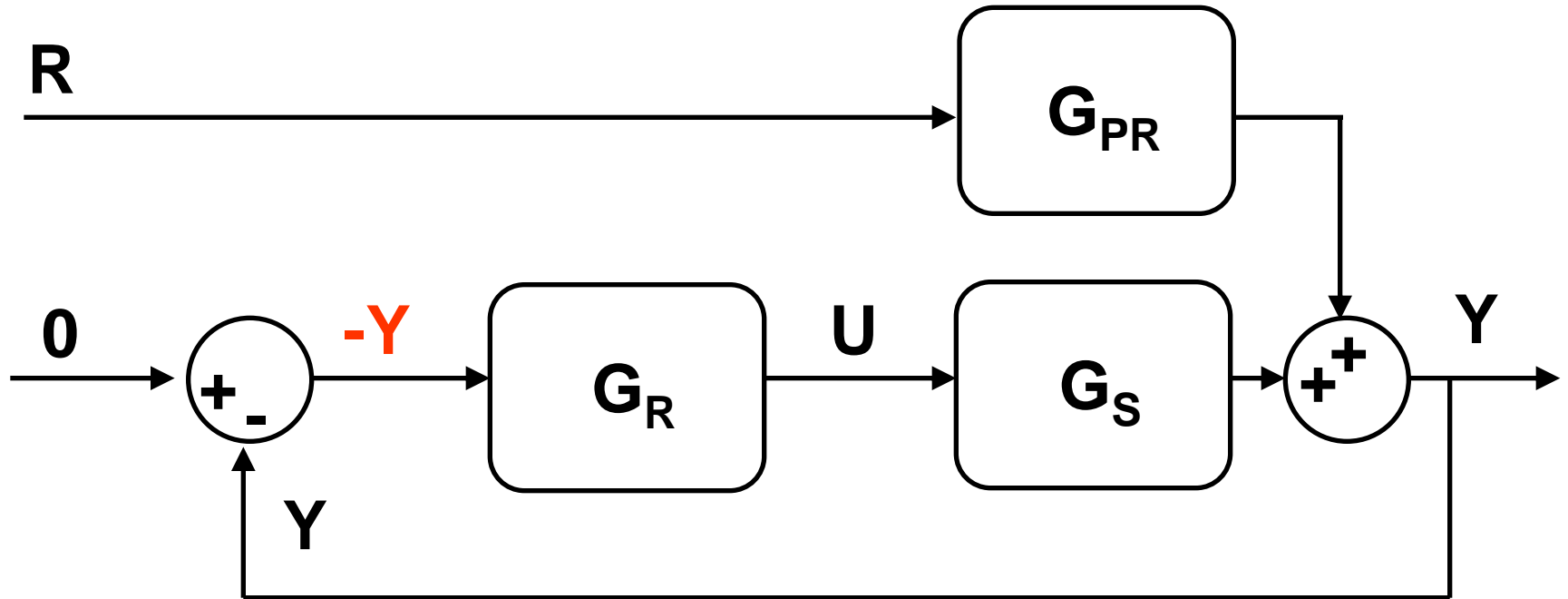

Prenos URO

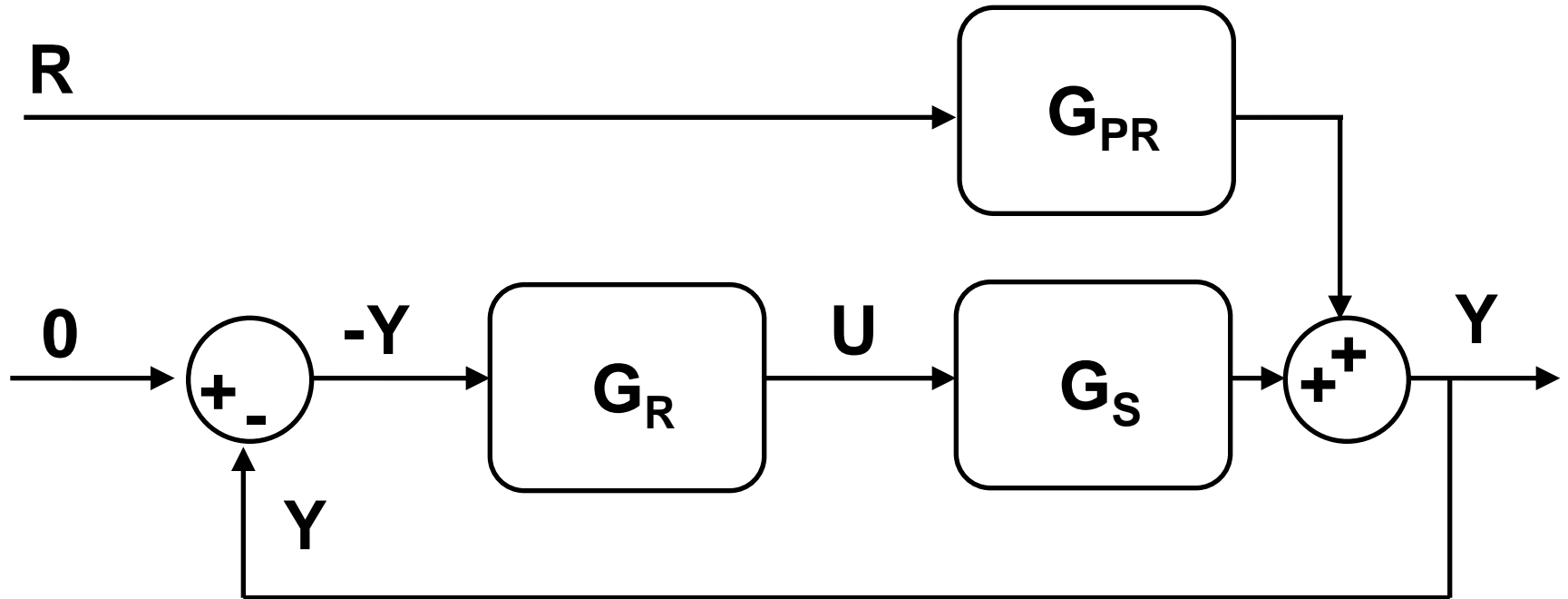

Prenos URO

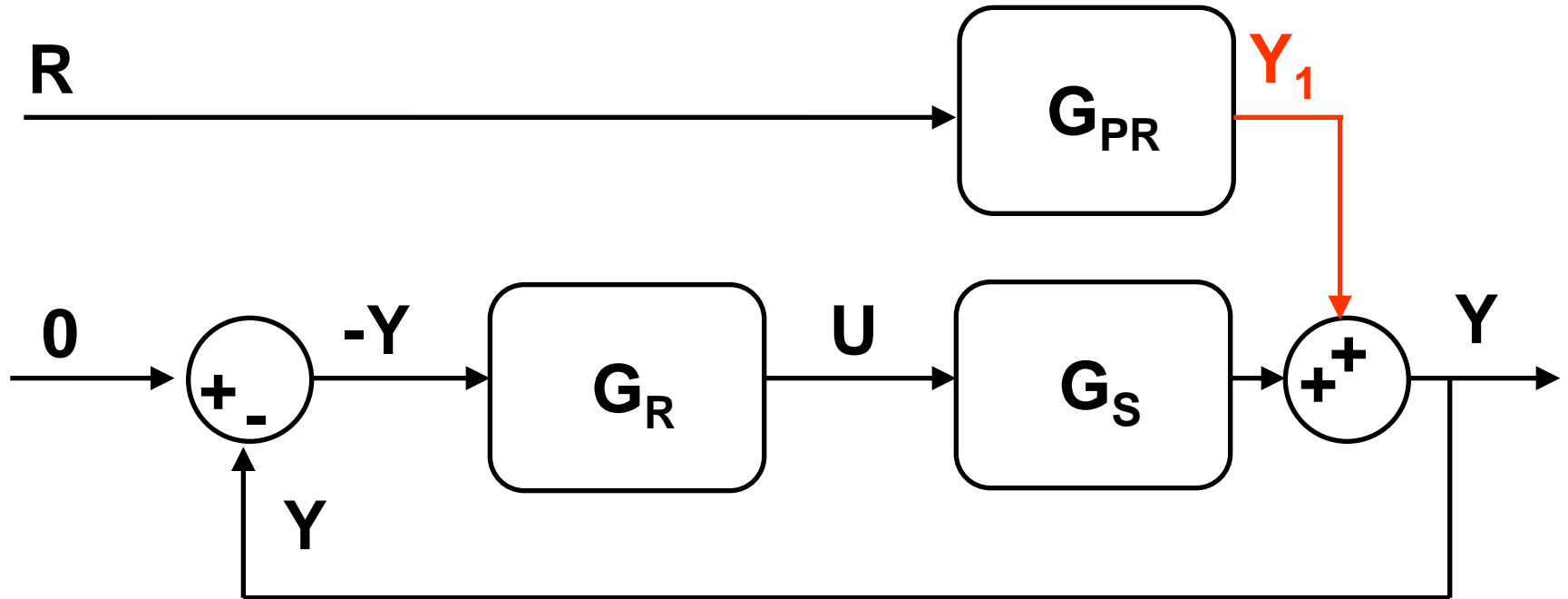

Prenos URO

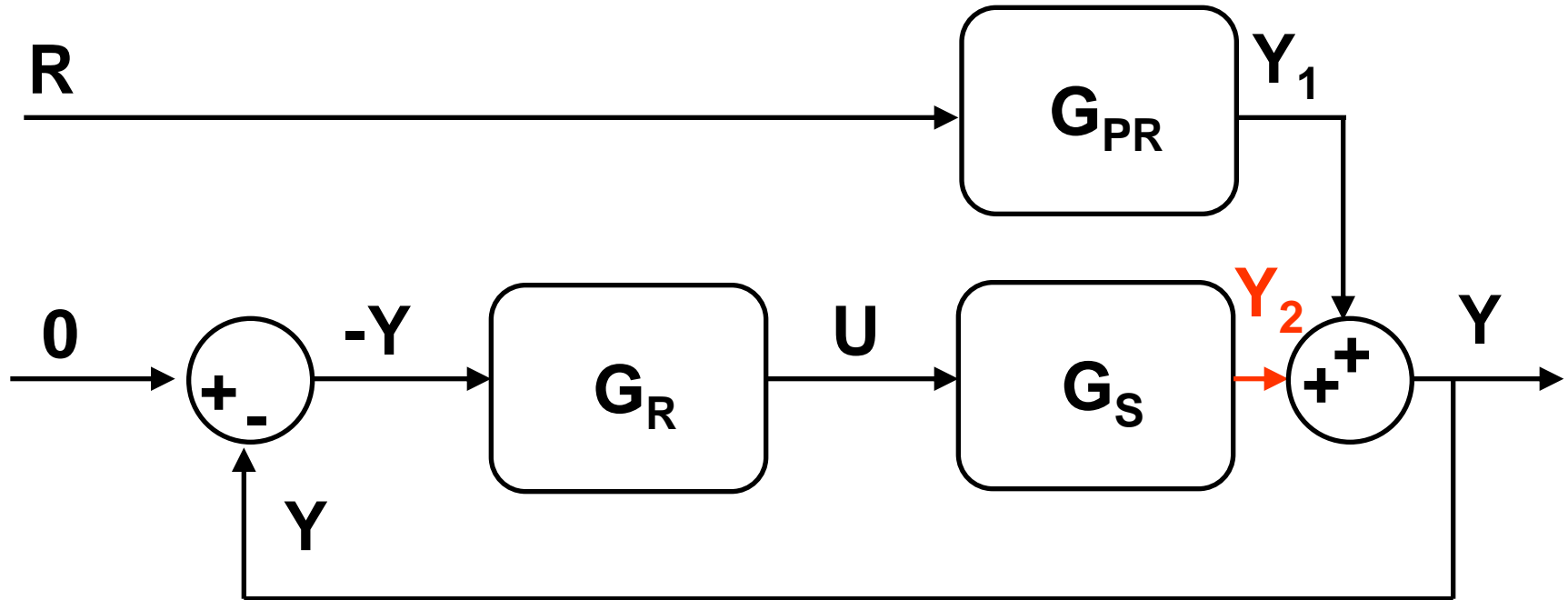

Prenos URO

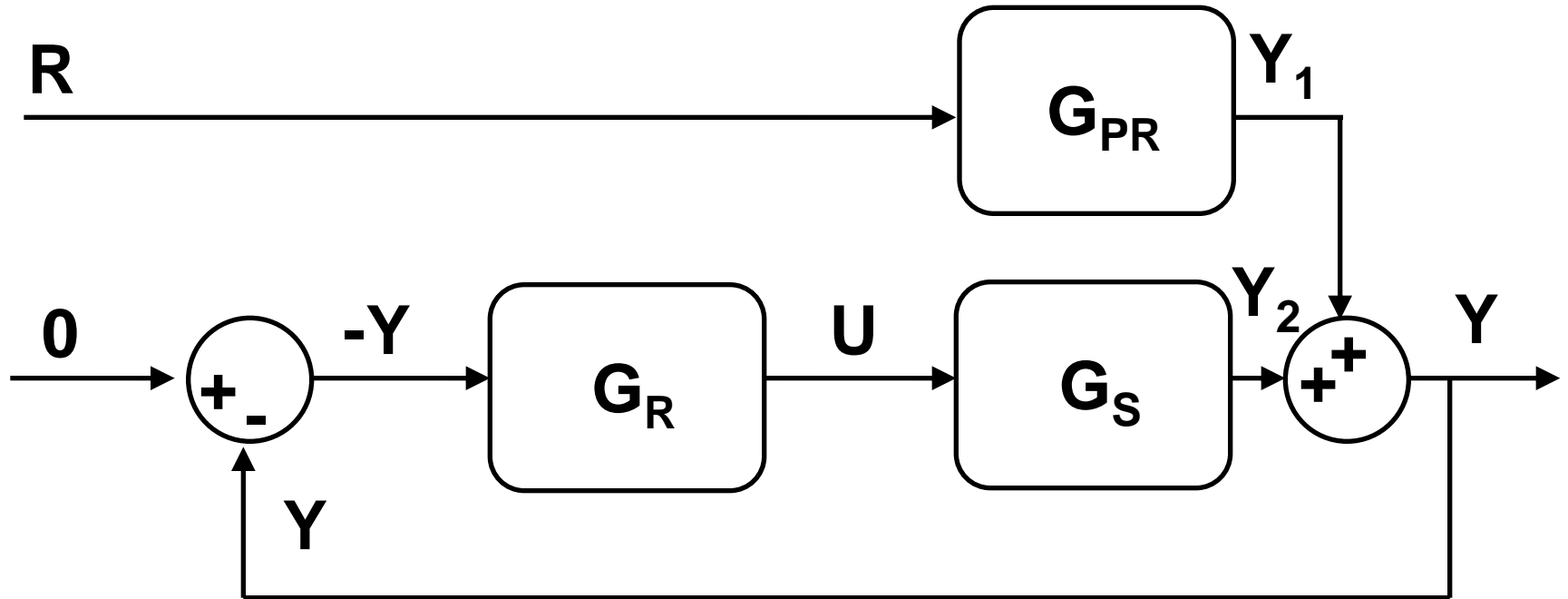

Prenos URO

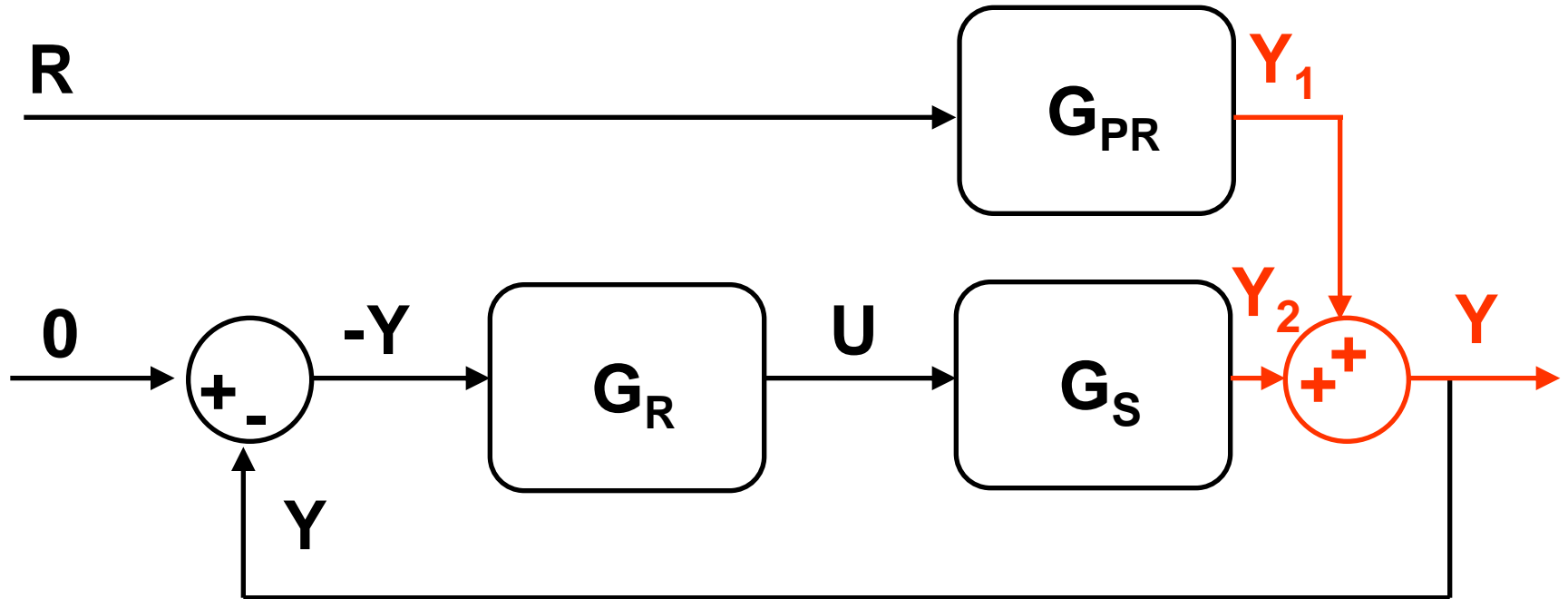

$$Y = Y_1 + Y_2$$

Prenos URO

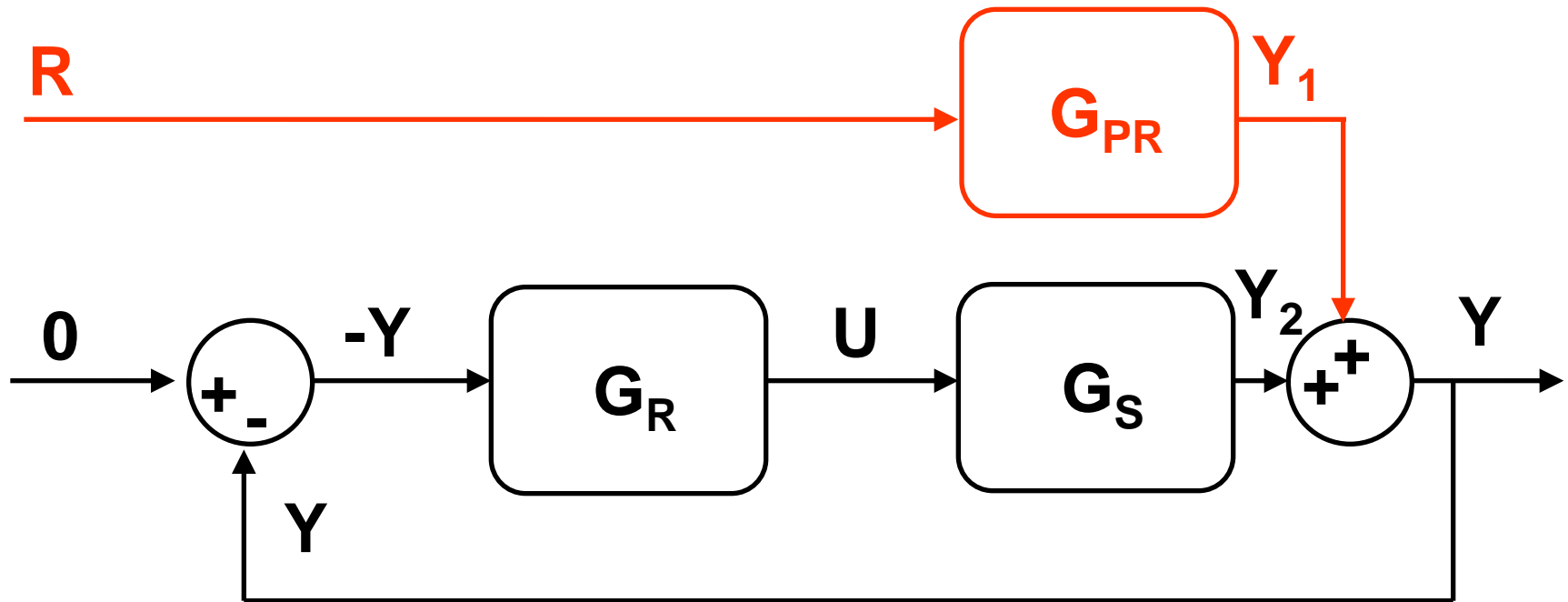

$$Y = Y_1 + Y_2 = G_{PR}R + Y_2$$

Prenos URO

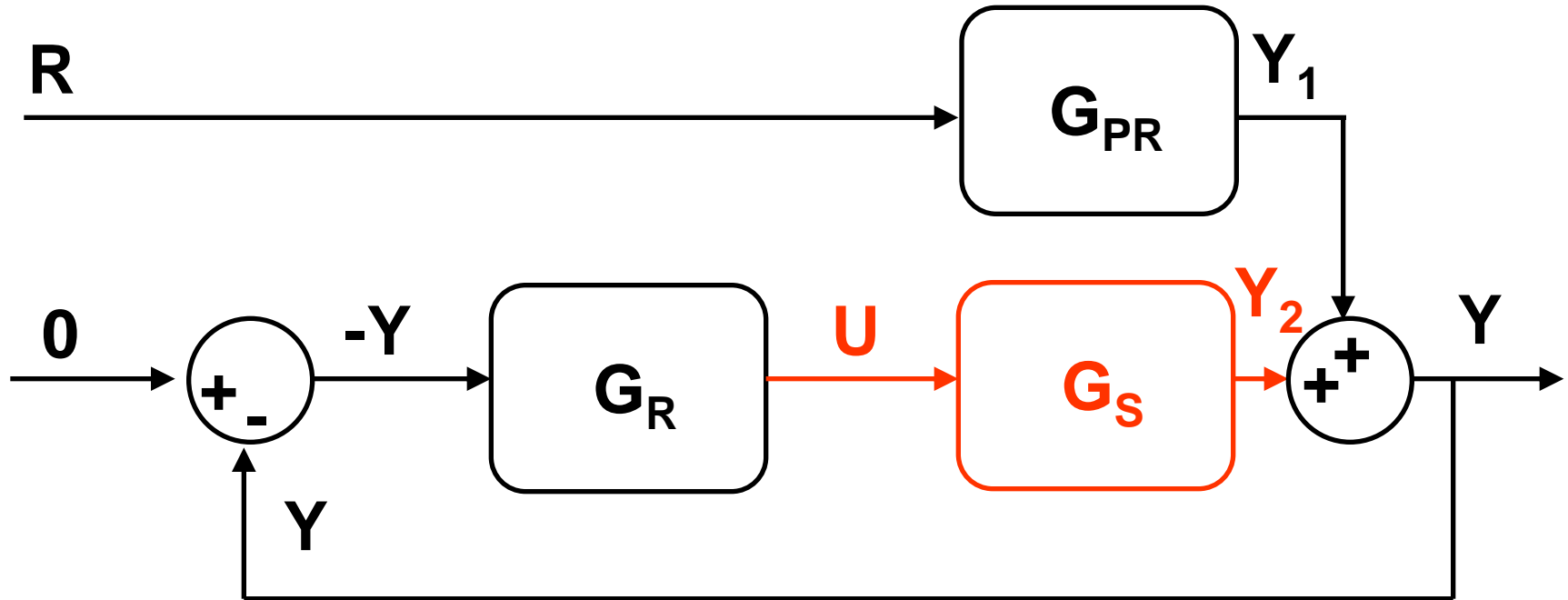

$$Y = Y_1 + Y_2 = G_{PR}R + G_S U$$

Prenos URO

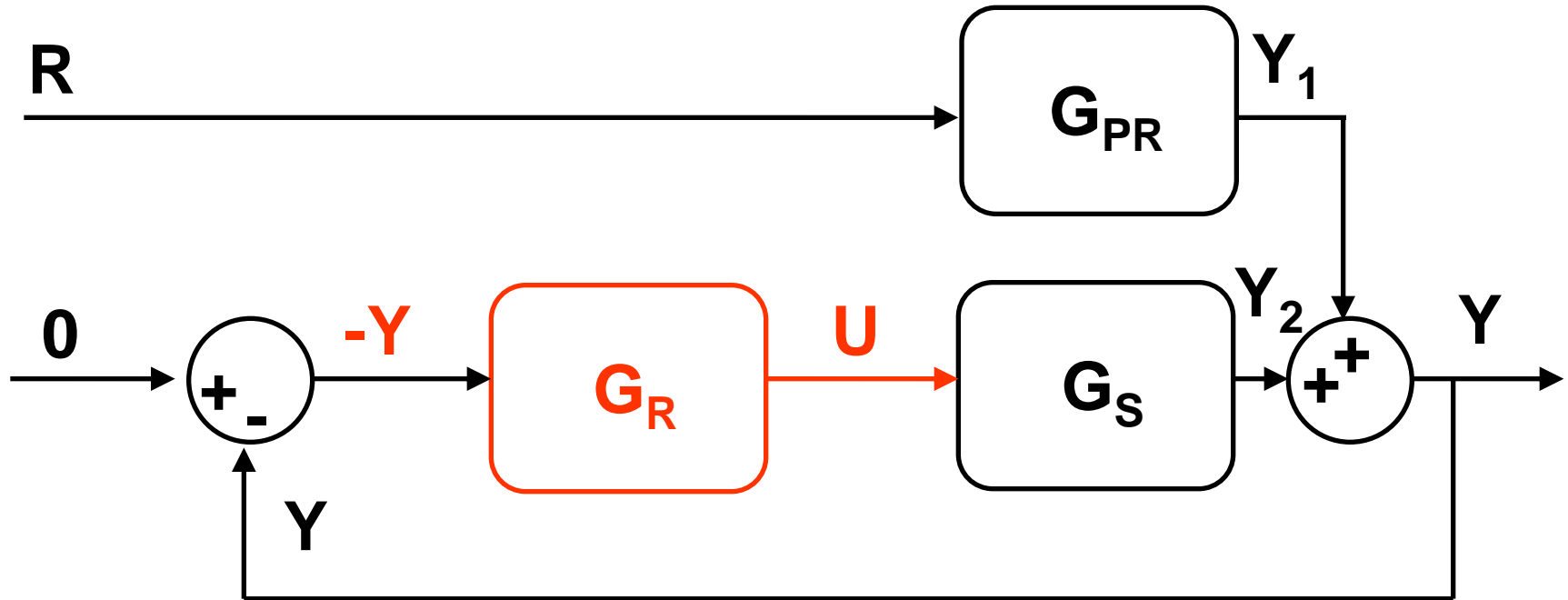

$$Y = Y_1 + Y_2 = G_{PR}R + G_S U = G_{PR}R - G_S G_R Y$$

Prenos URO

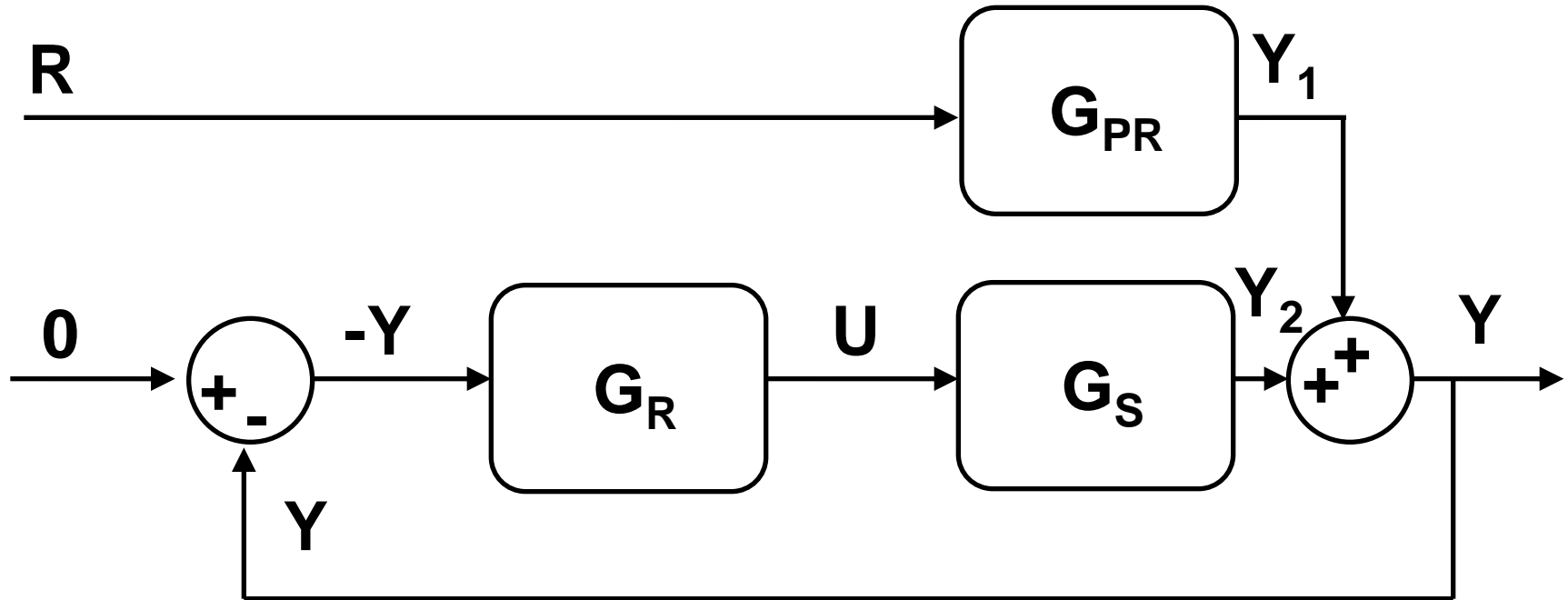

$$Y = Y_1 + Y_2 = G_{PR}R + G_S U = G_{PR}R - G_S G_R Y$$

Prenos URO

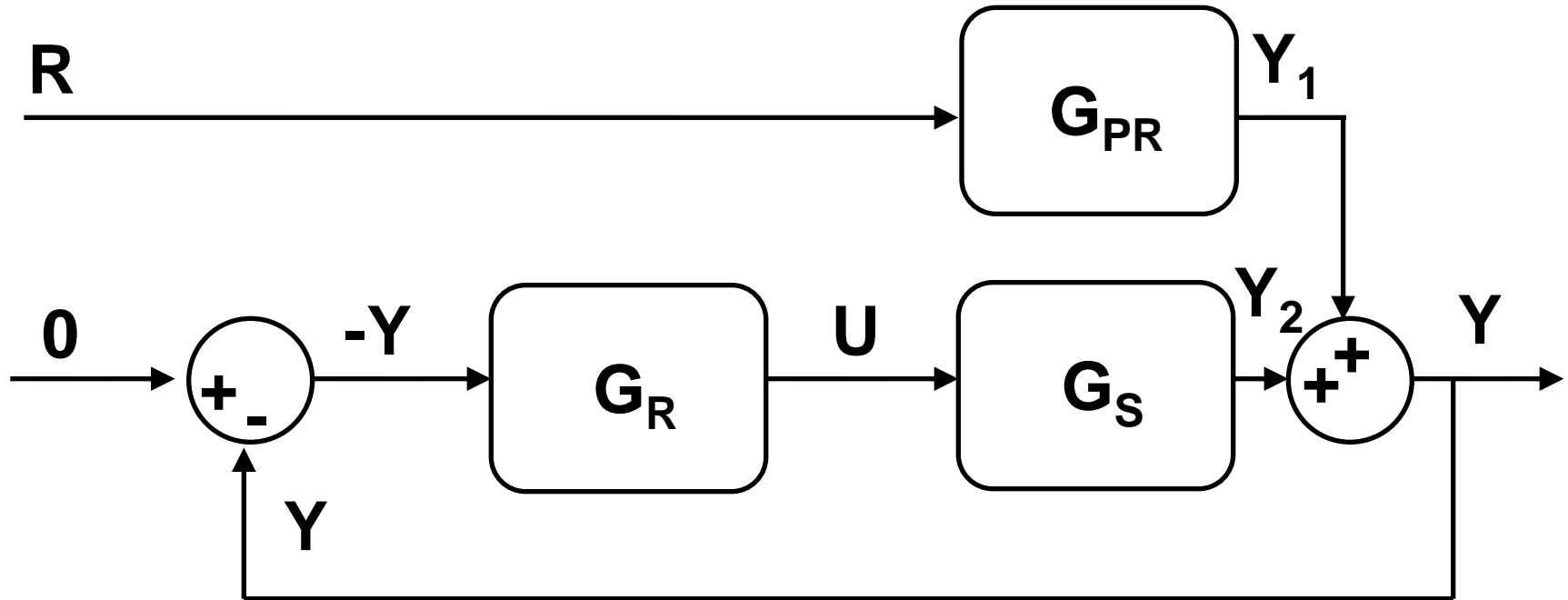

$$Y = G_{PR}R - G_S G_R Y$$

Prenos URO

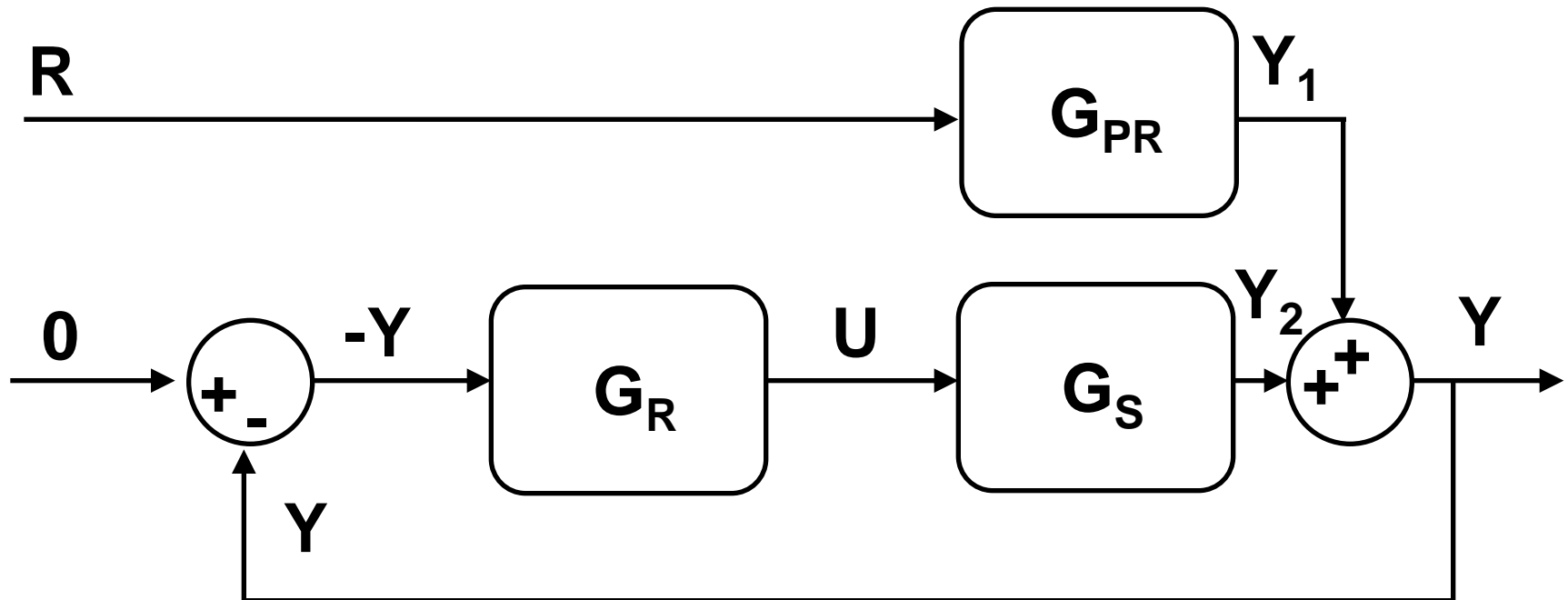

$$Y = G_{PR}R - G_S G_R Y \quad / \quad + G_S G_R Y$$

Prenos URO

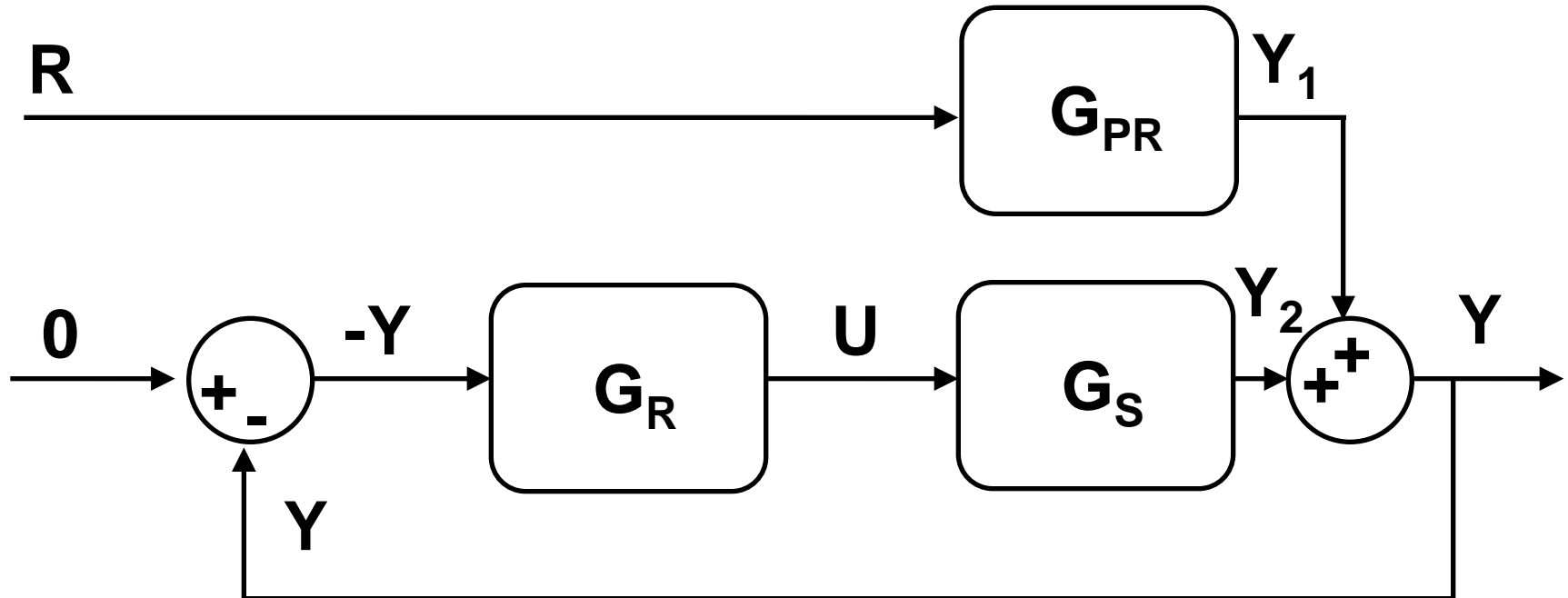

$$Y + G_S G_R Y = G_{PR} R$$

Prenos URO

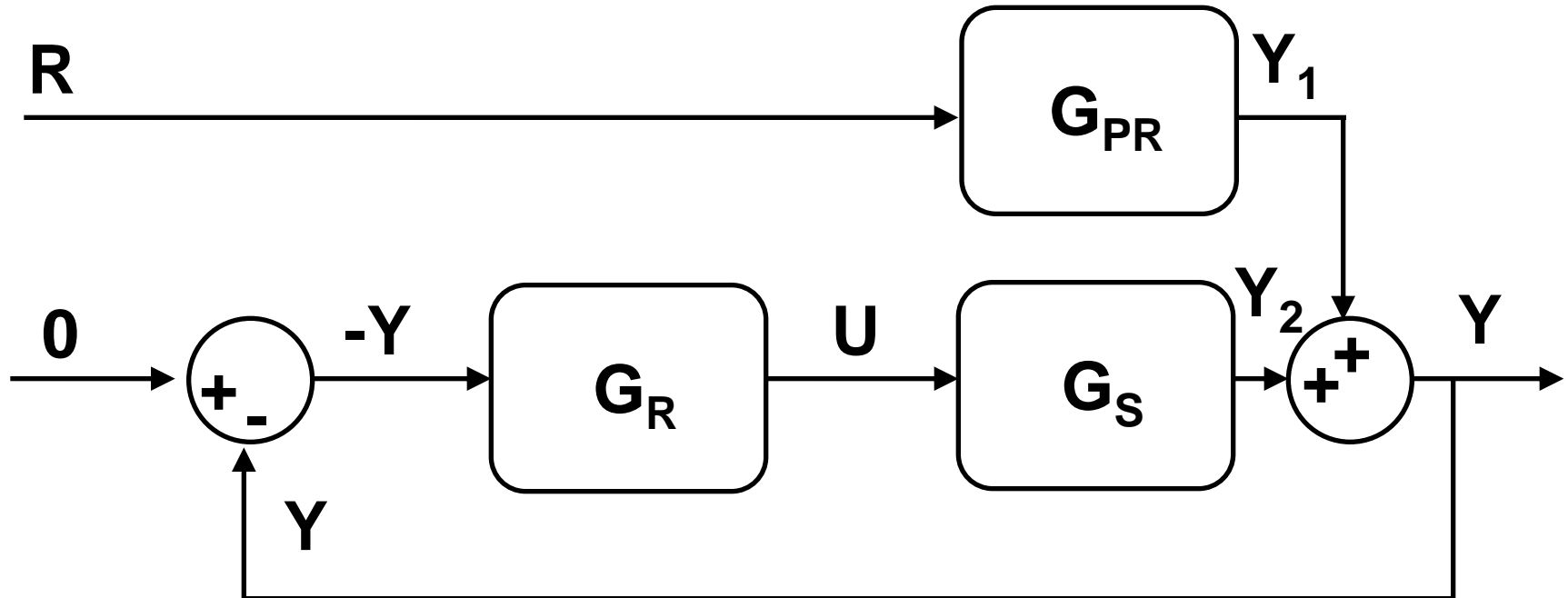

$$Y(1 + G_S G_R) = G_{PR} R$$

Prenos URO

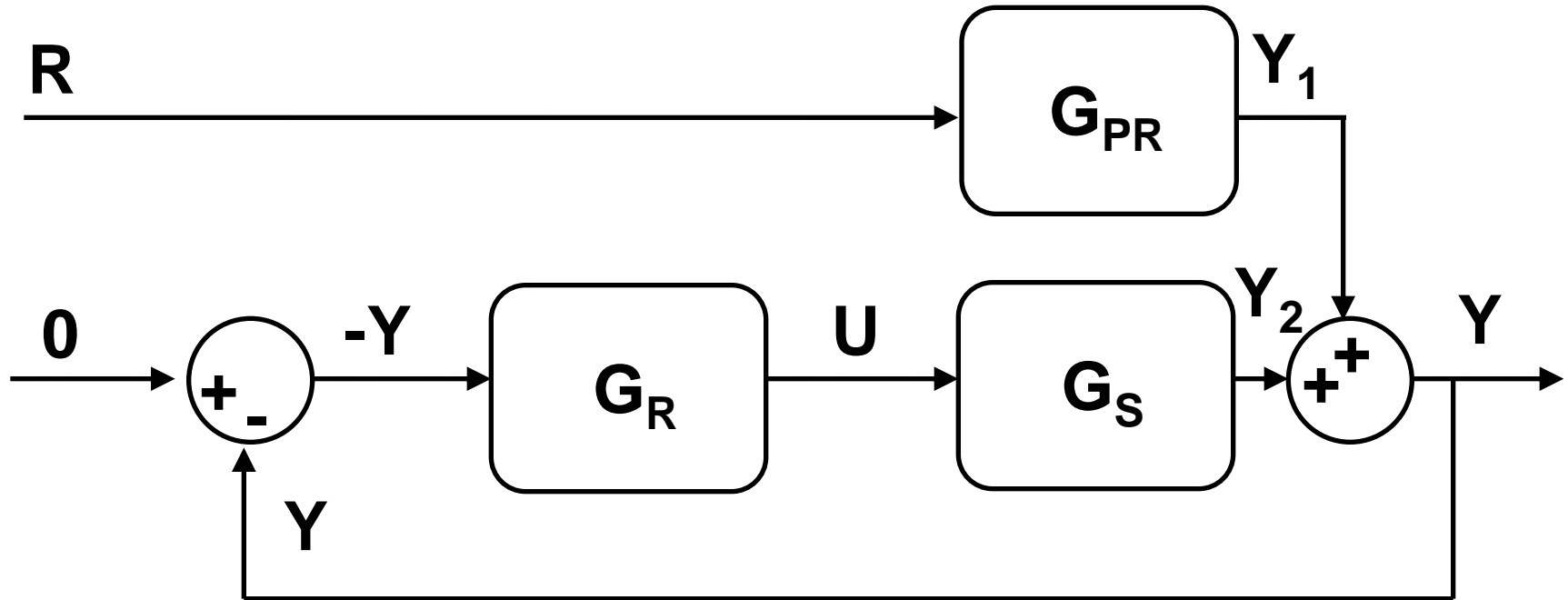

$$Y / R = G_{PR} / (1 + G_S G_R)$$

Prenos URO

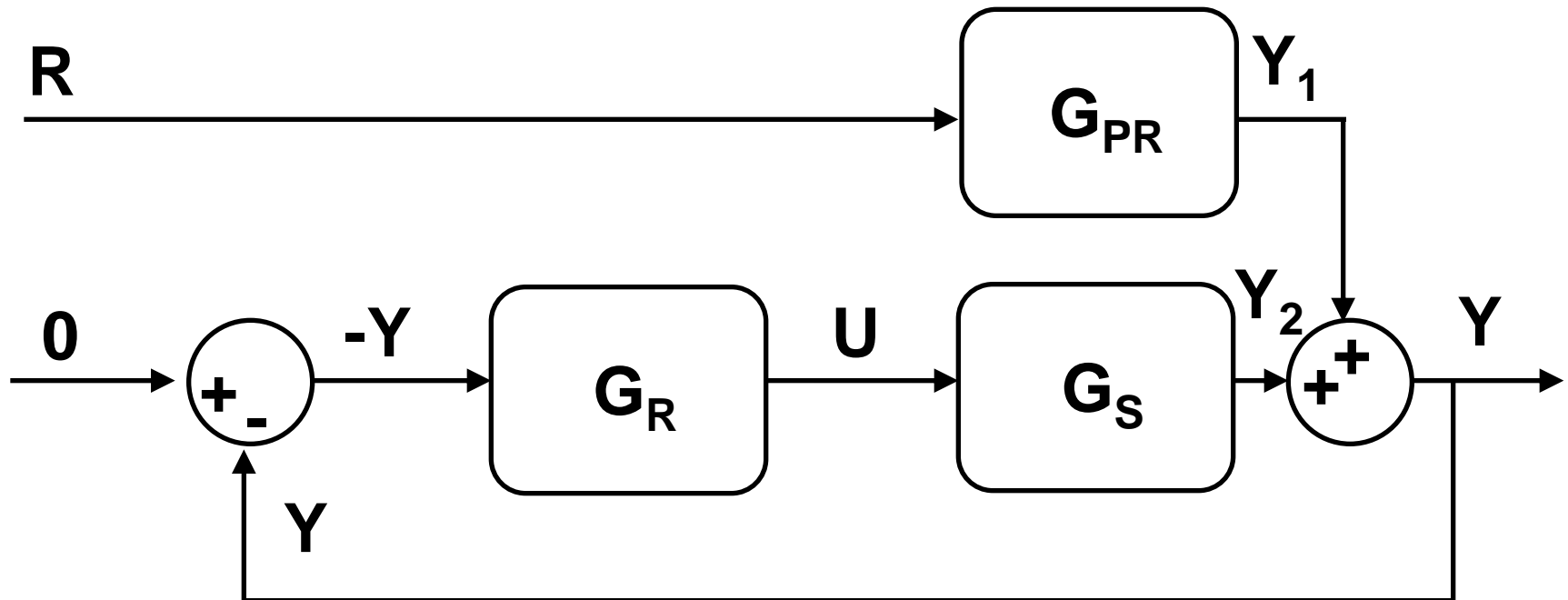

$$G_{YR} = \frac{Y}{R} = \frac{G_{PR}}{1 + G_R G_S}$$

CHR URO

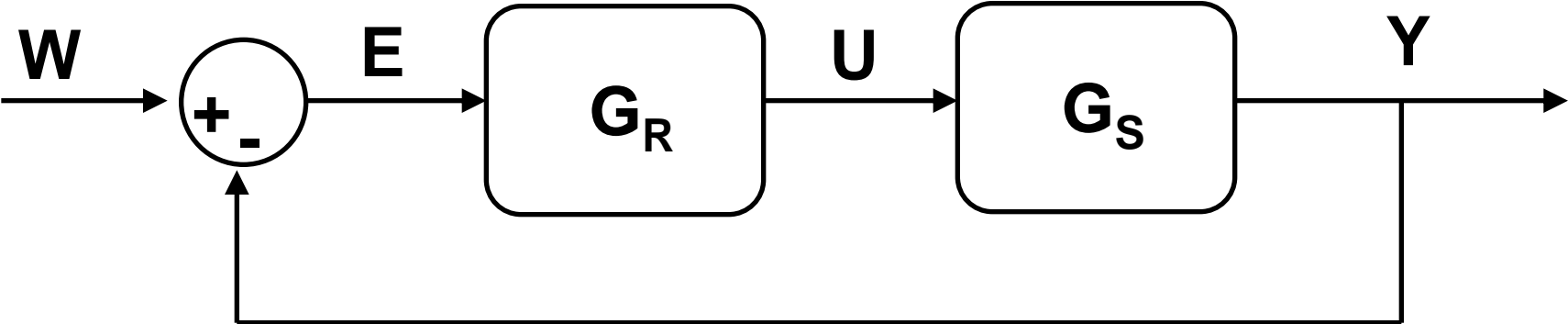

$$G_{URO} = \frac{G_R G_S}{1 + G_R G_S}$$

CHR URO

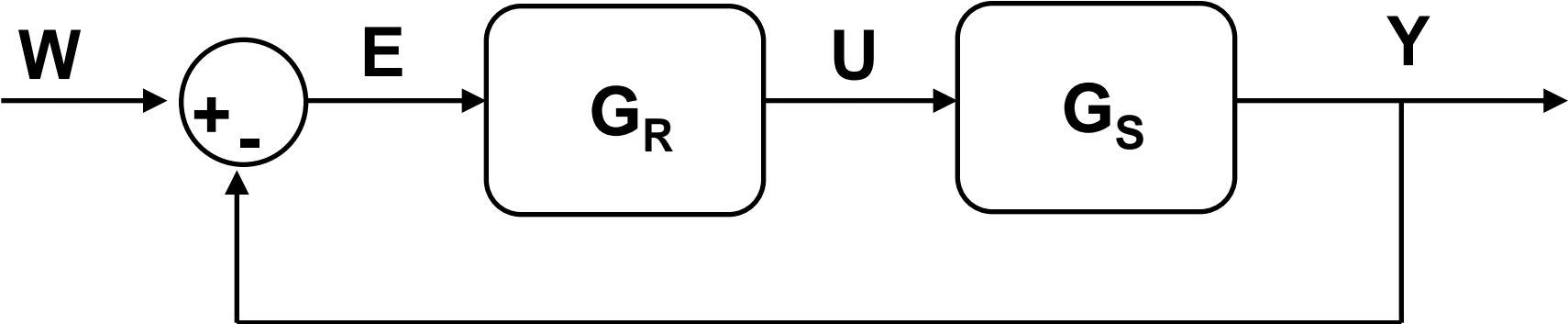

$$G_{URO} = \frac{G_R G_S}{1 + G_R G_S} \Rightarrow 1 + G_R G_S = 0$$

CHR URO

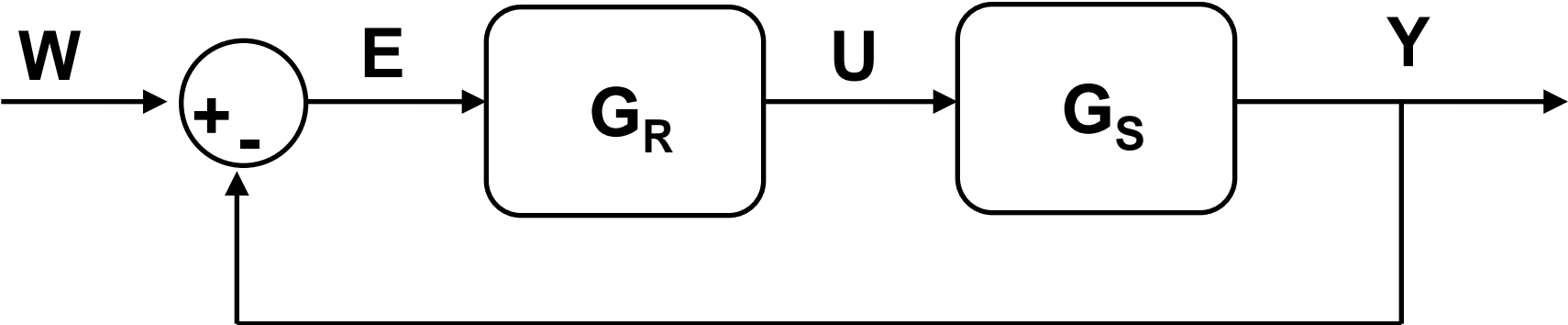

$$G_{URO} = \frac{G_R G_S}{1 + G_R G_S} \Rightarrow 1 + G_R G_S = 0$$

CHR URO

CHR URO

URO je stabilný, ak všetky korene CHR URO majú zápornú reálnu časť

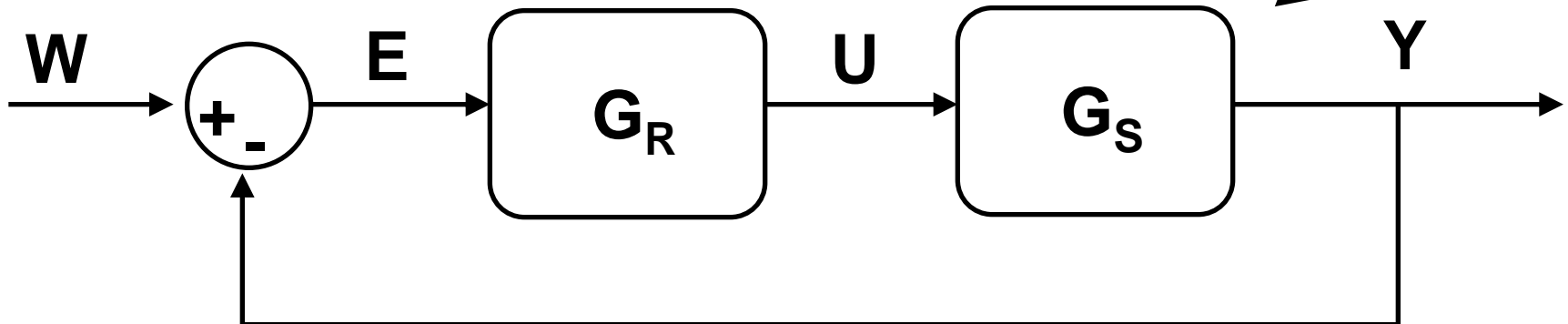

$$G_{URO} = \frac{G_R G_S}{1 + G_R G_S} \Rightarrow 1 + G_R G_S = 0$$

Zákon riadenia

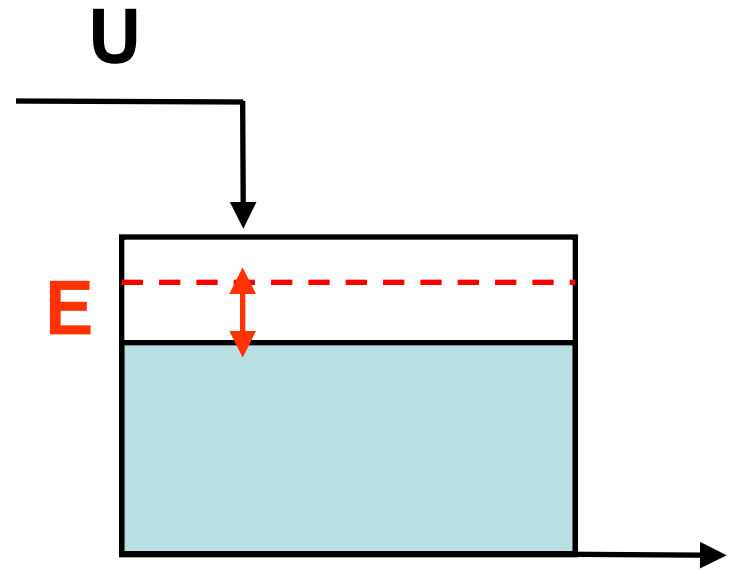

Zákon riadenia

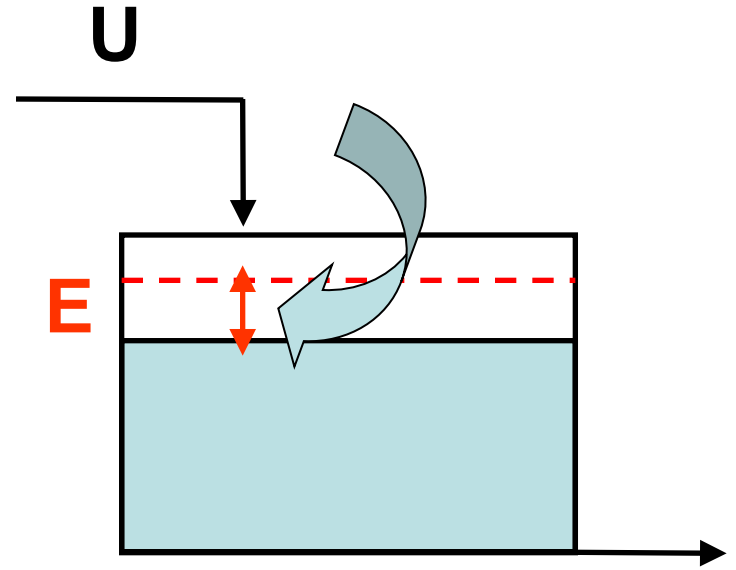

Zákon riadenia

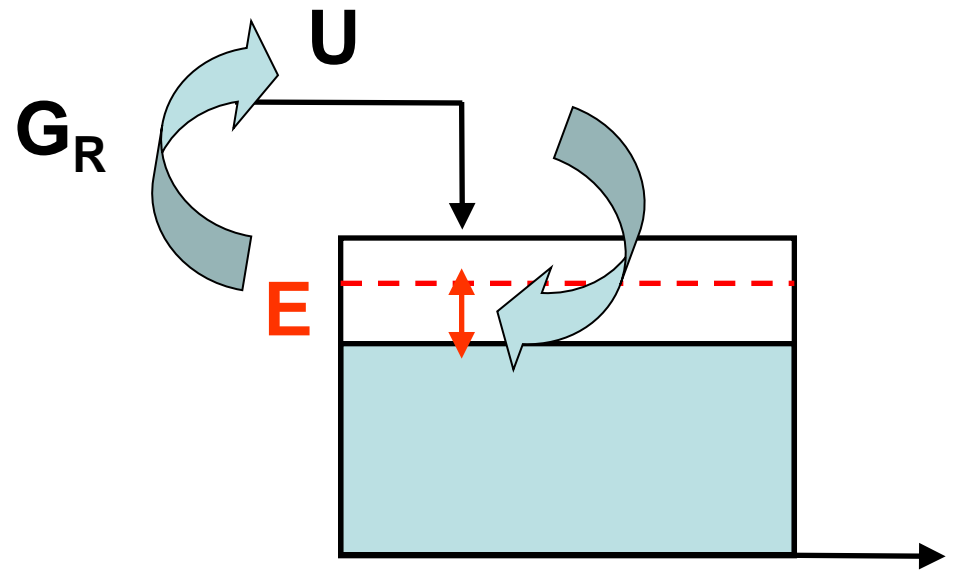

Zákon riadenia

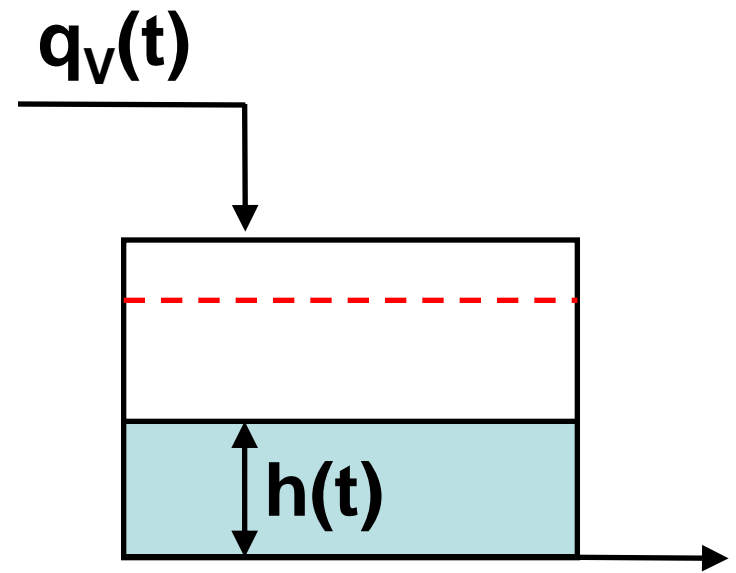

Zákon riadenia

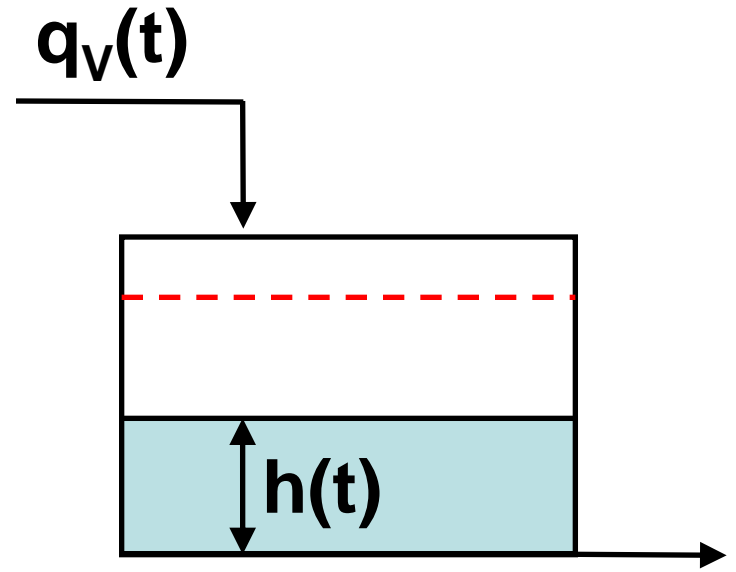
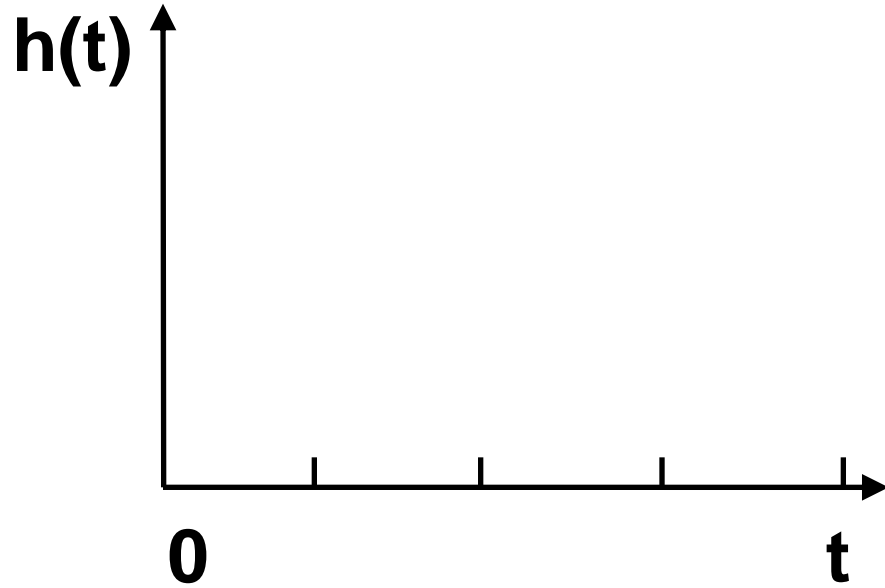

Zákon riadenia

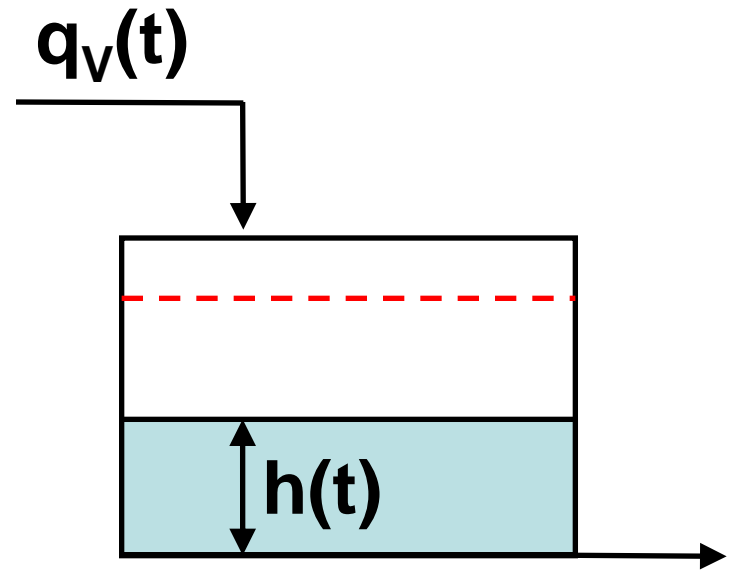
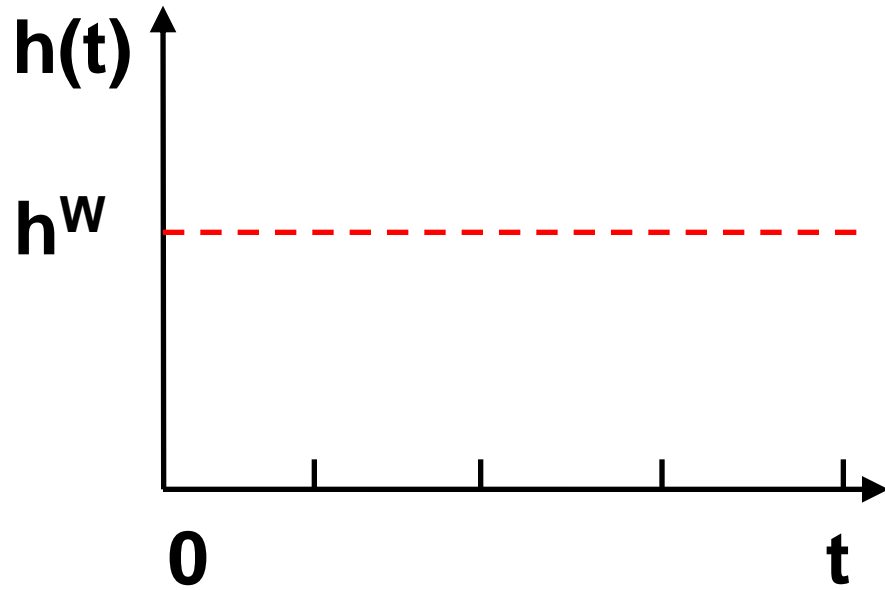

Zákon riadenia

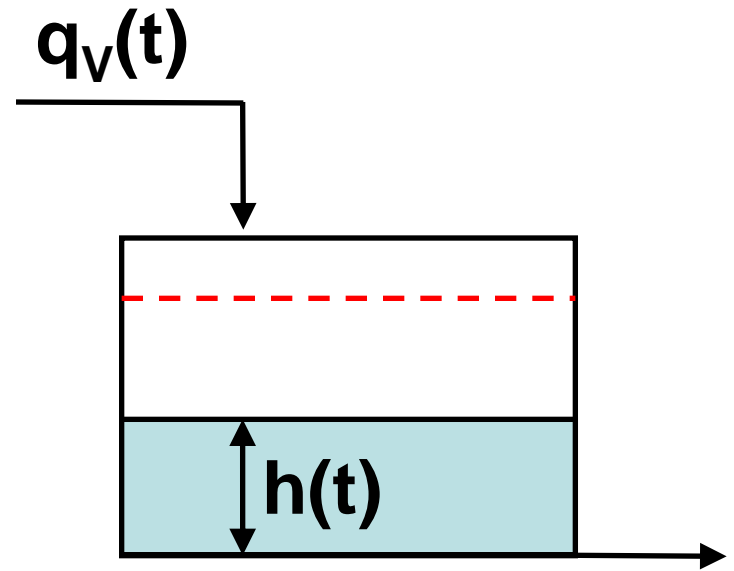
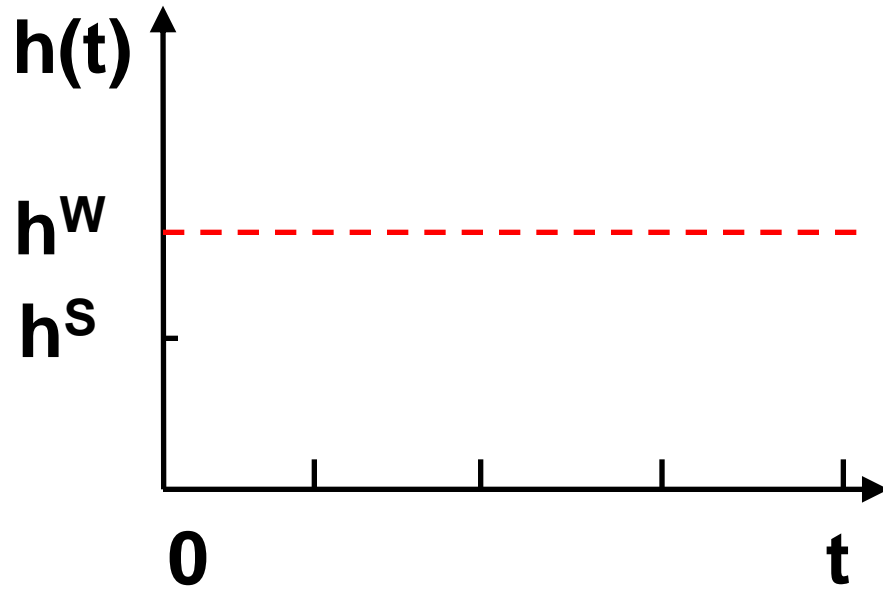

Zákon riadenia

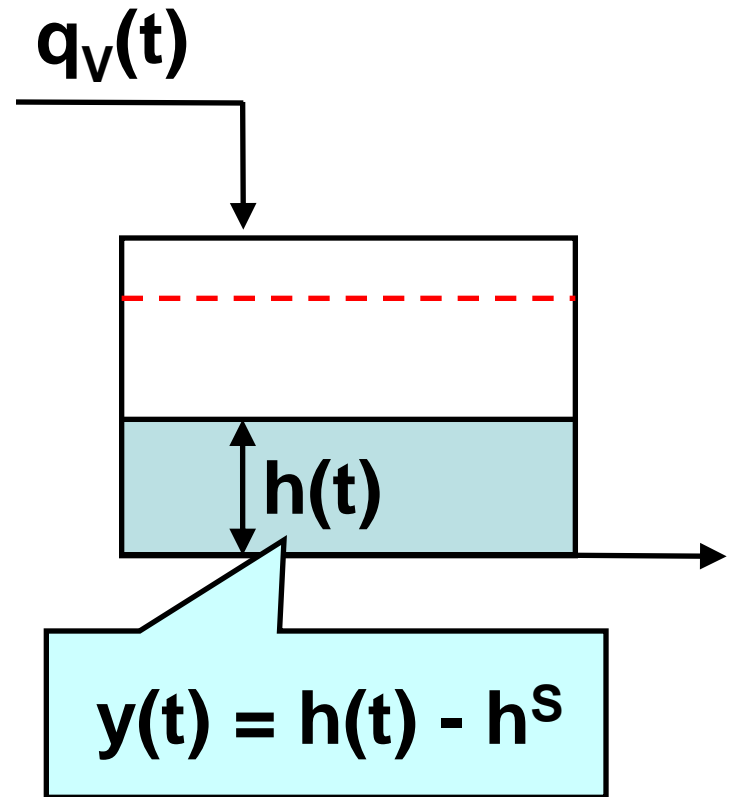
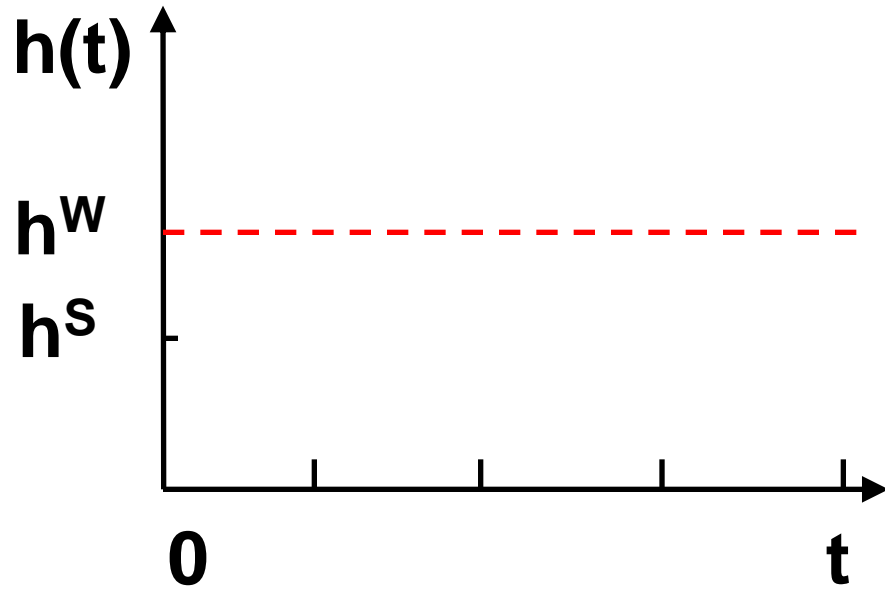

Zákon riadenia

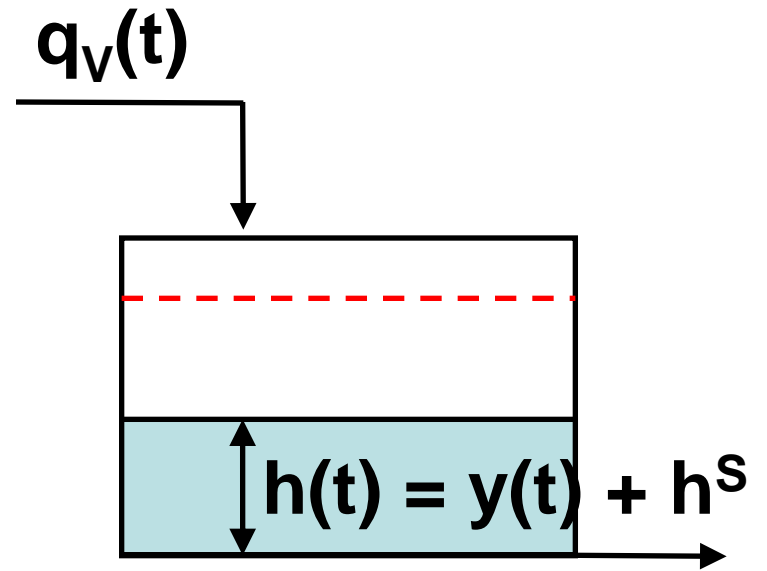
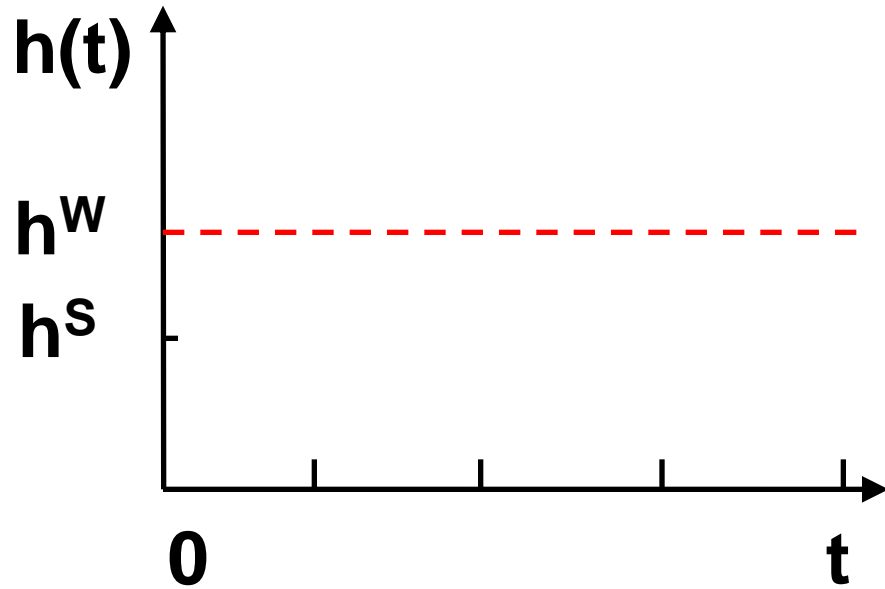

Zákon riadenia

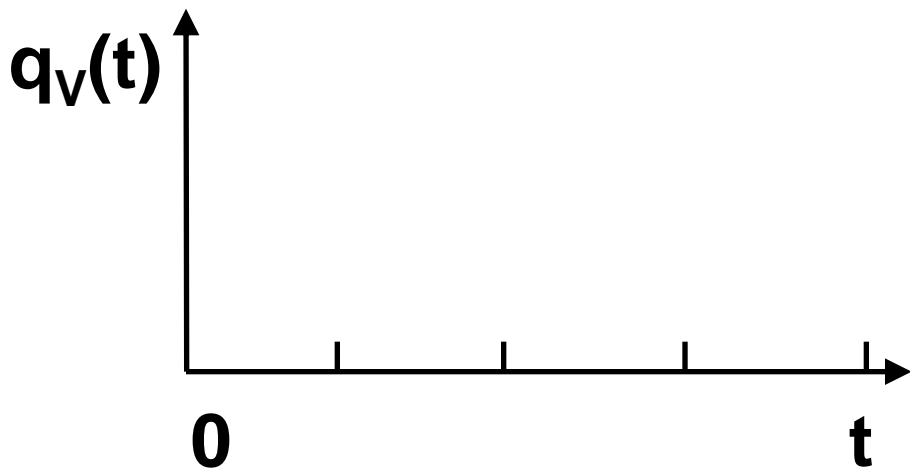
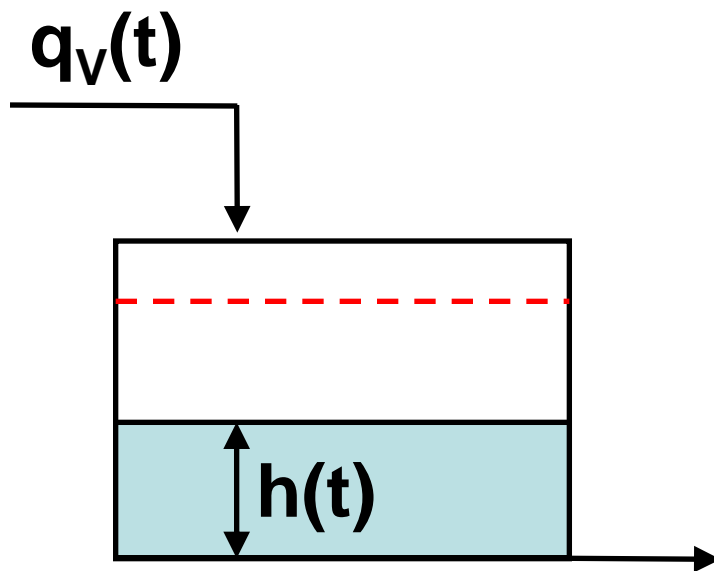
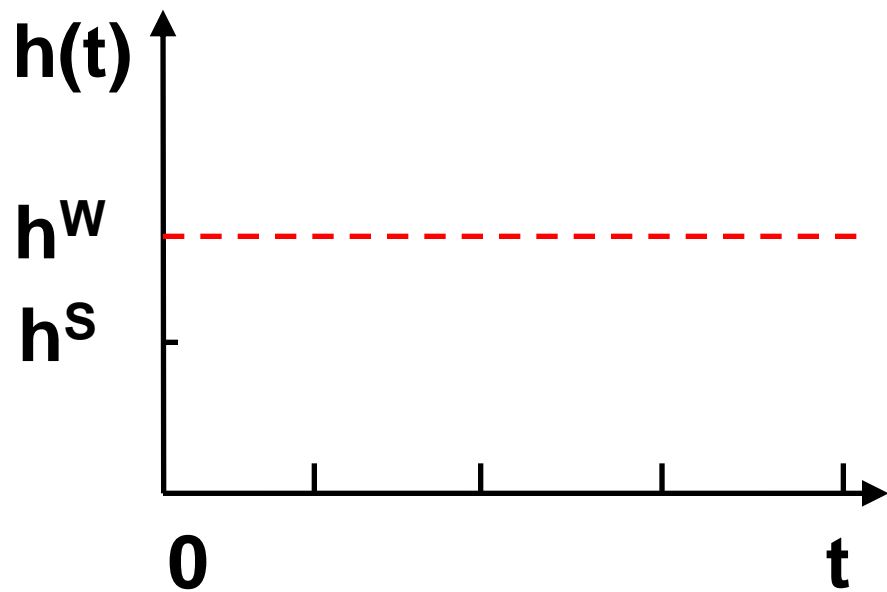

Zákon riadenia

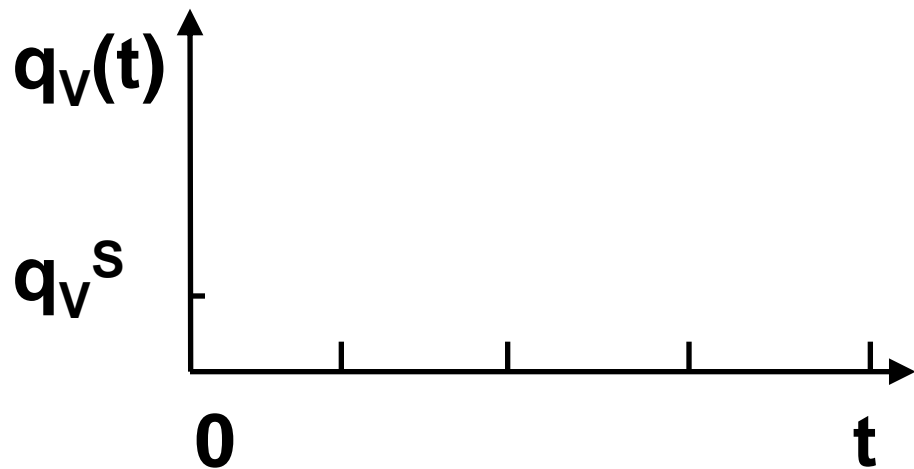
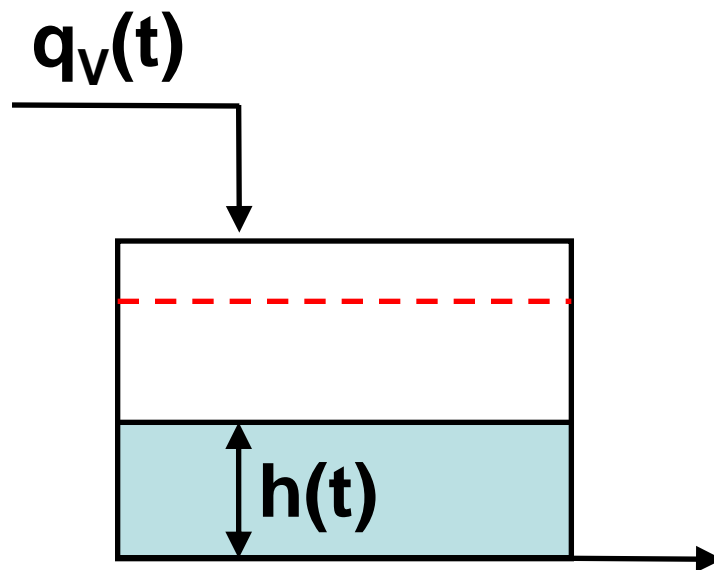
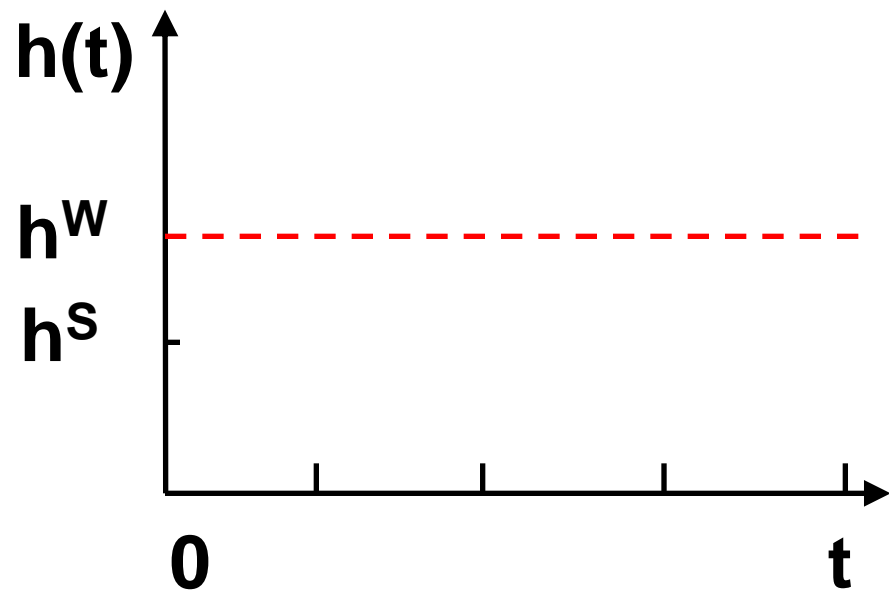

Zákon riadenia

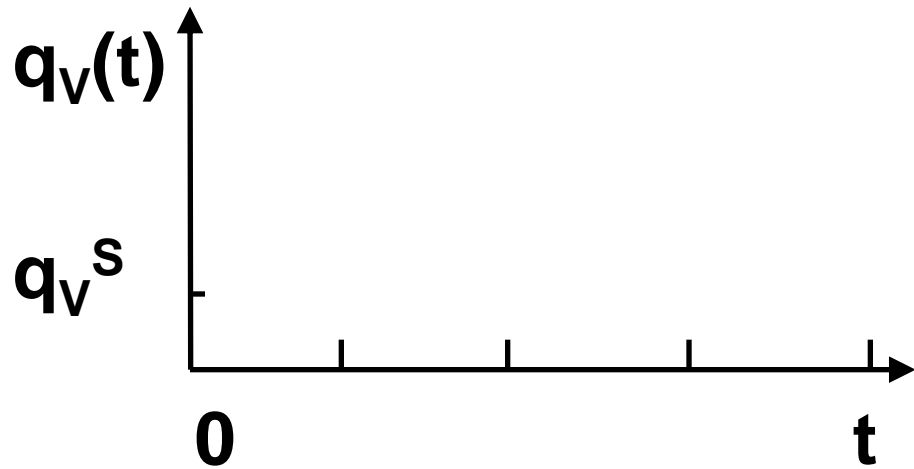
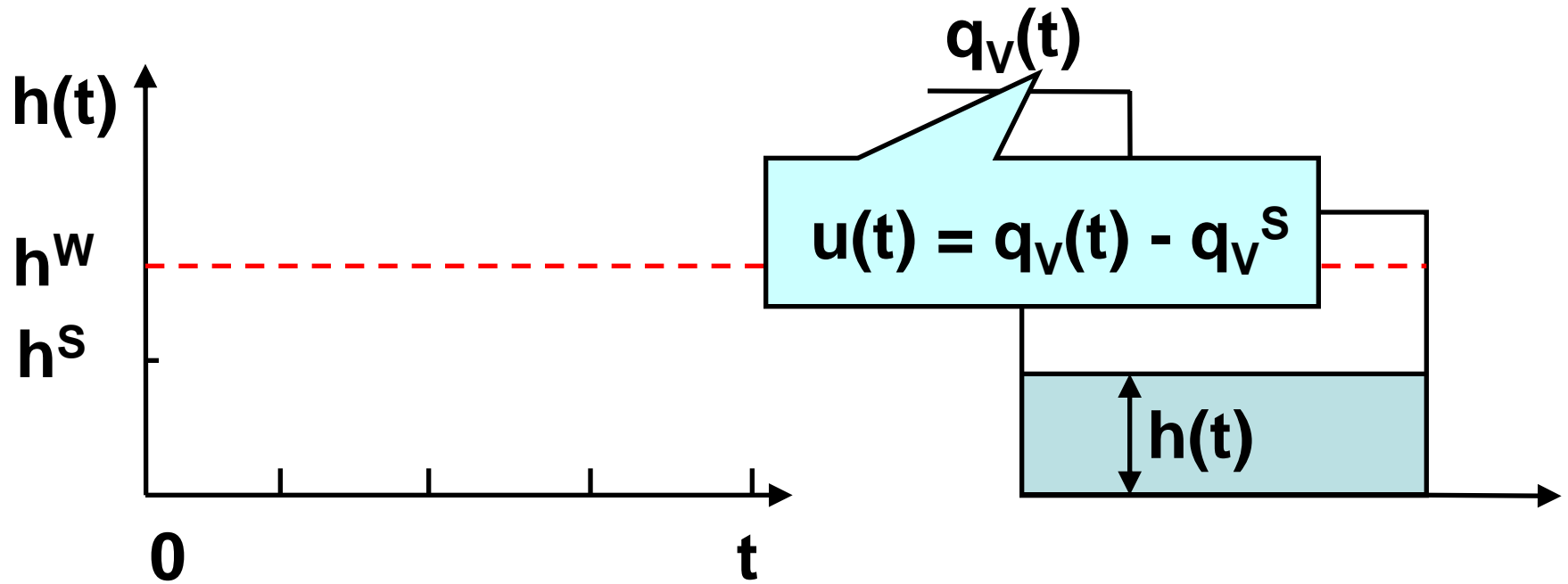

Zákon riadenia

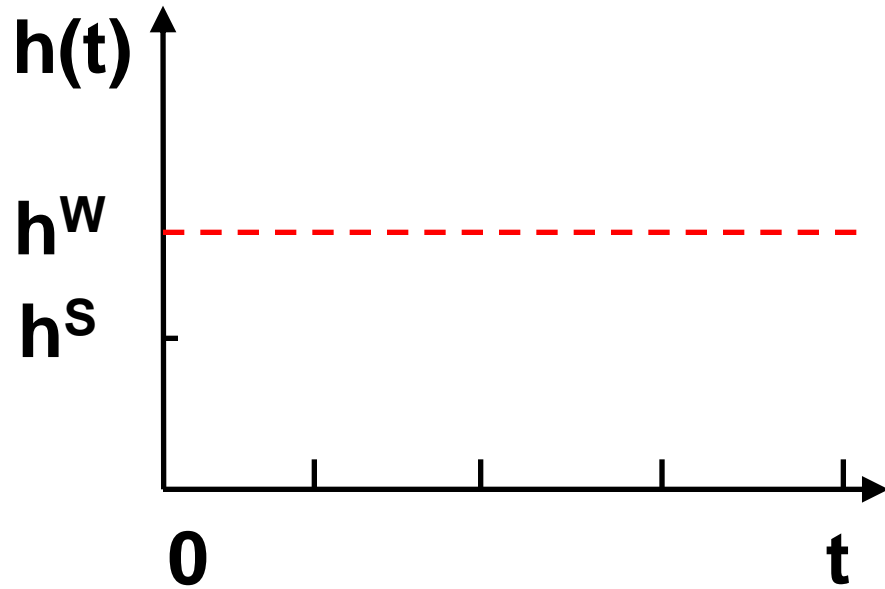

$$q_v(t) = q_v^S + u(t)$$

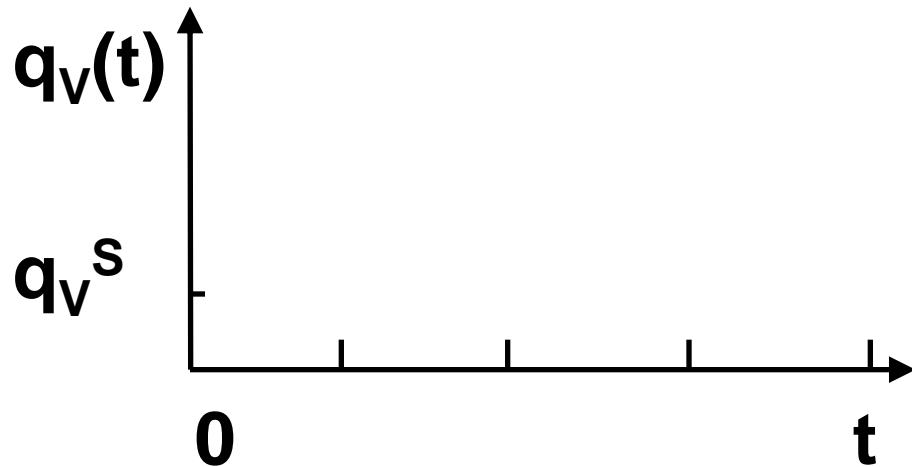
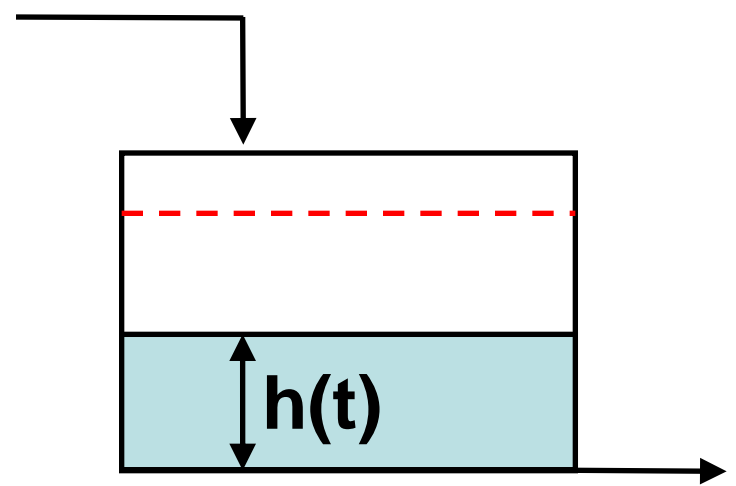

Zákon riadenia

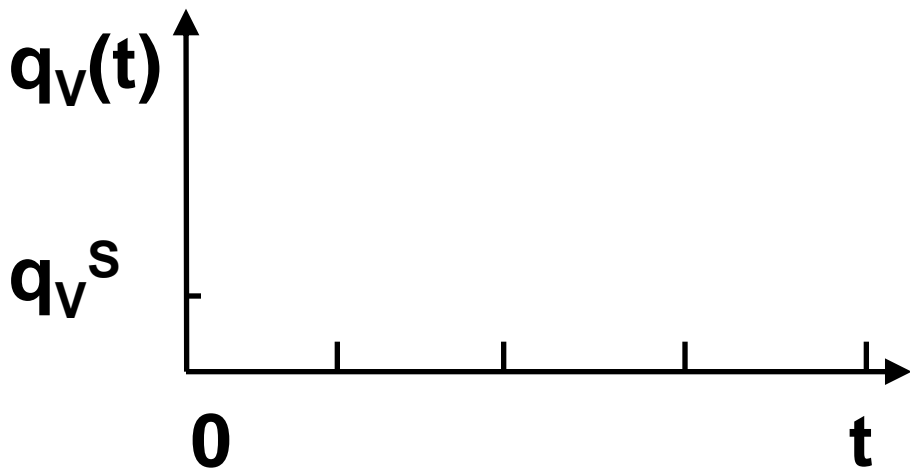
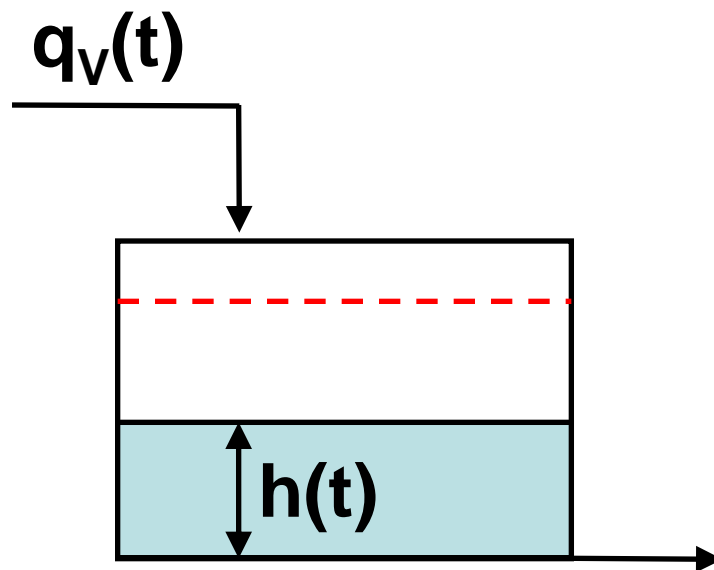
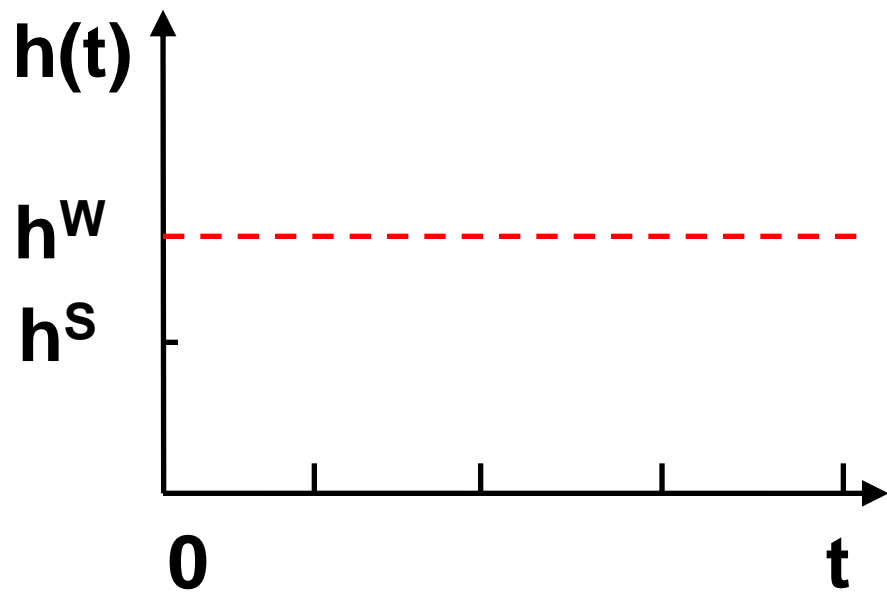

Zákon riadenia

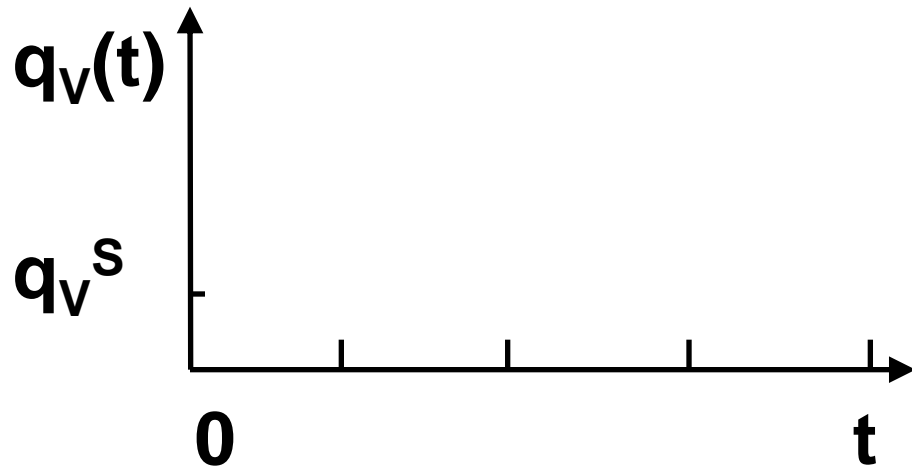
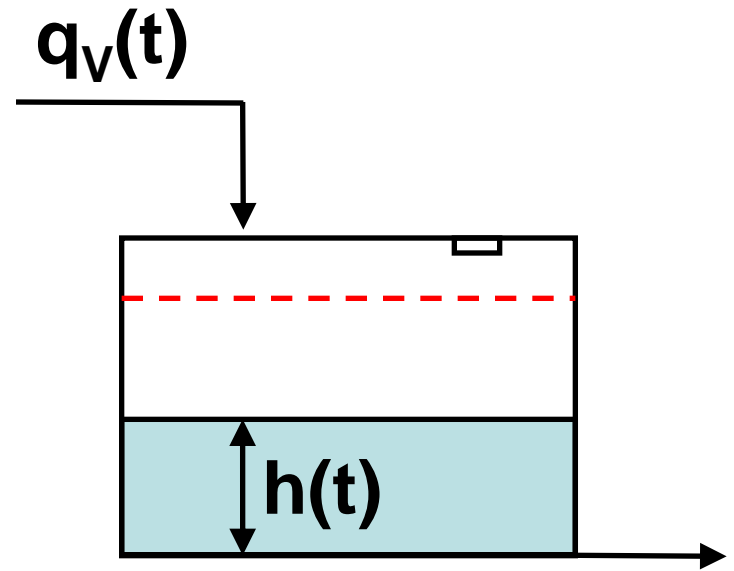
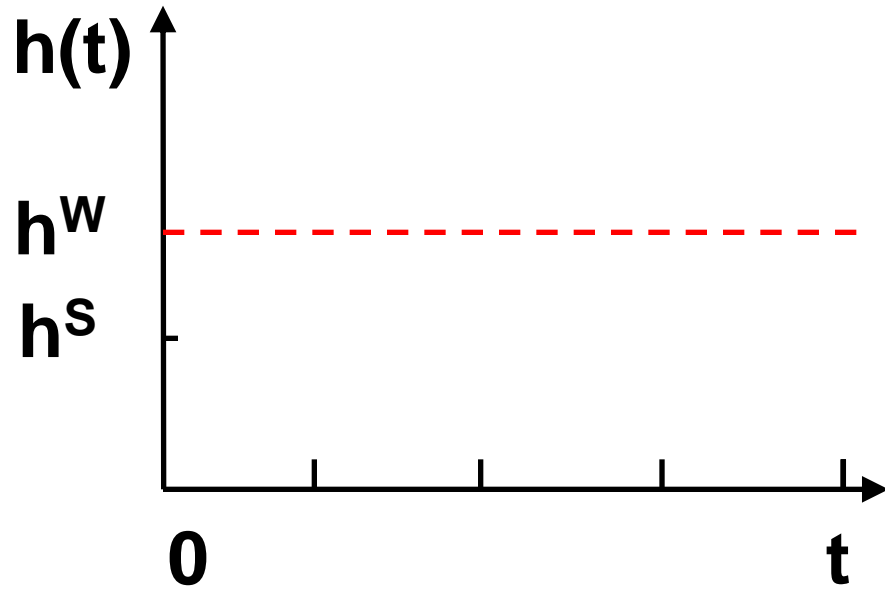

Zákon riadenia

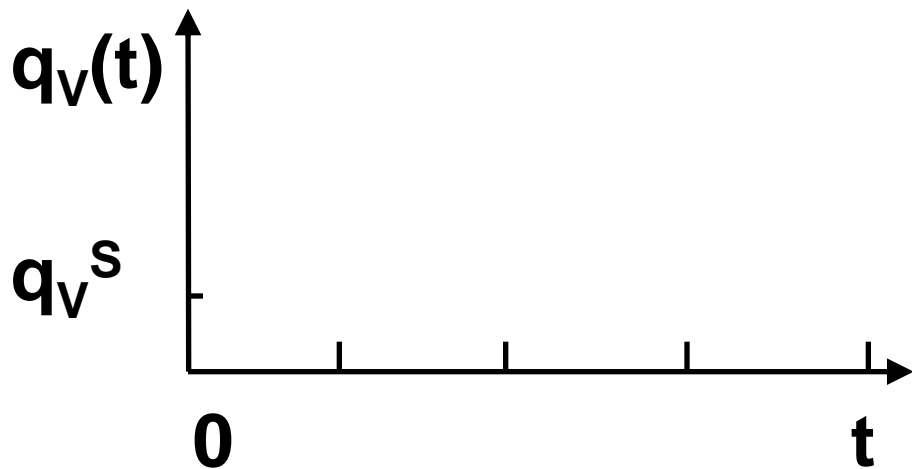
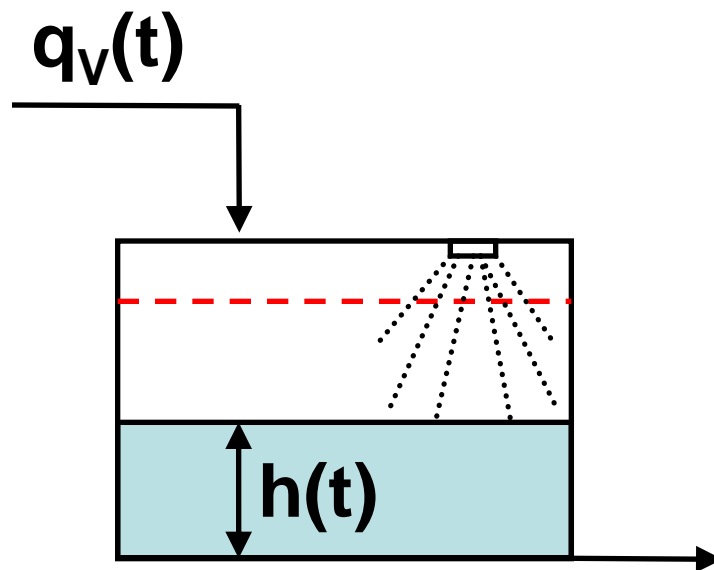
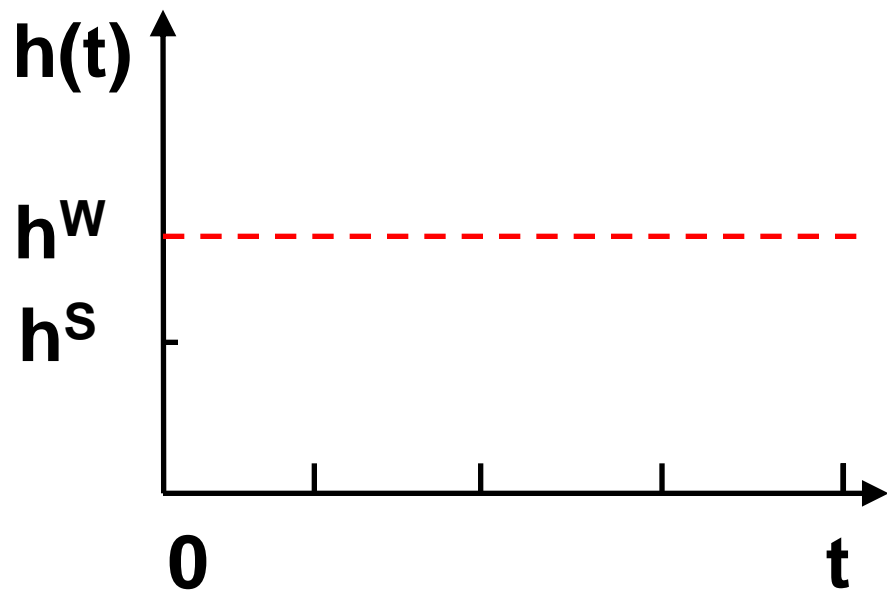

Zákon riadenia

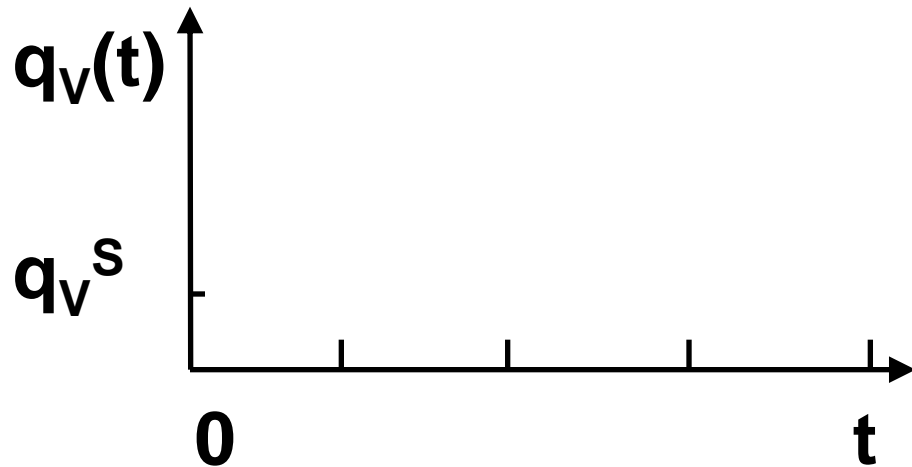
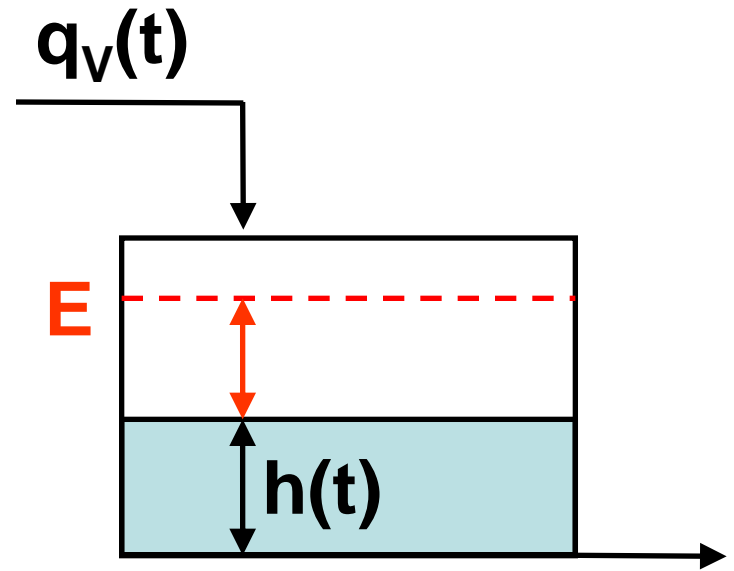
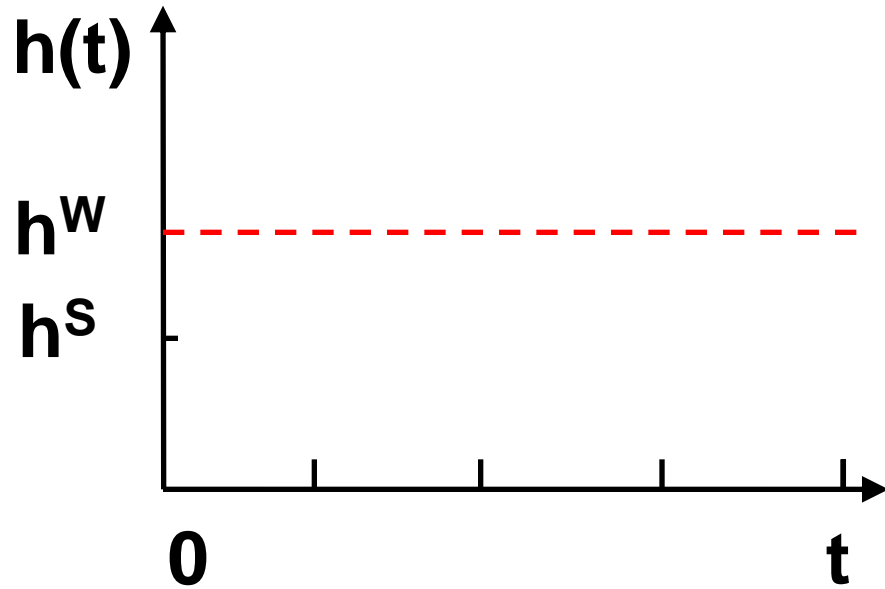

Zákon riadenia

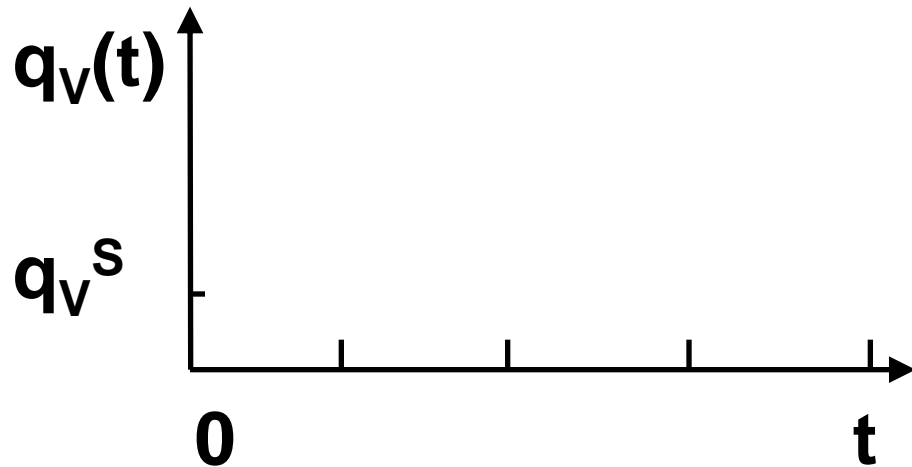
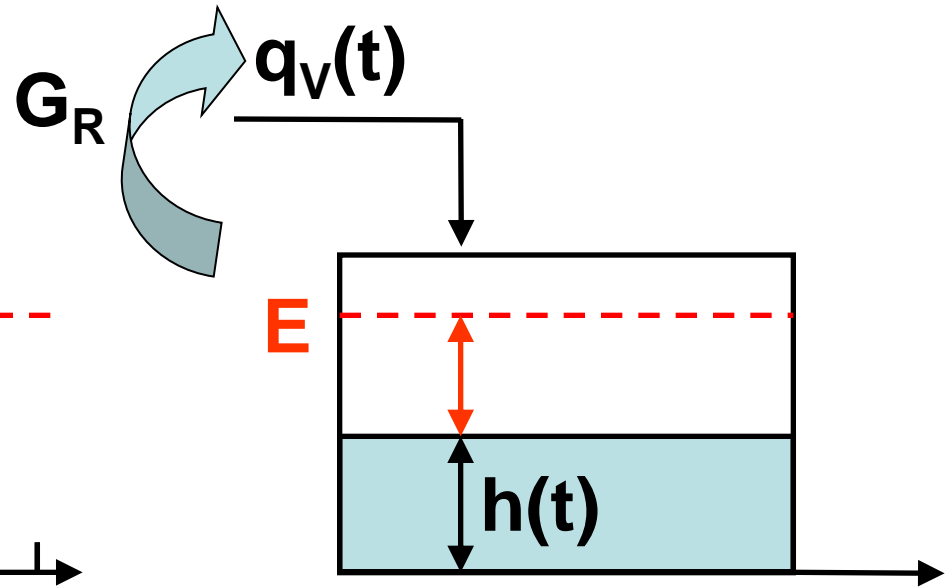
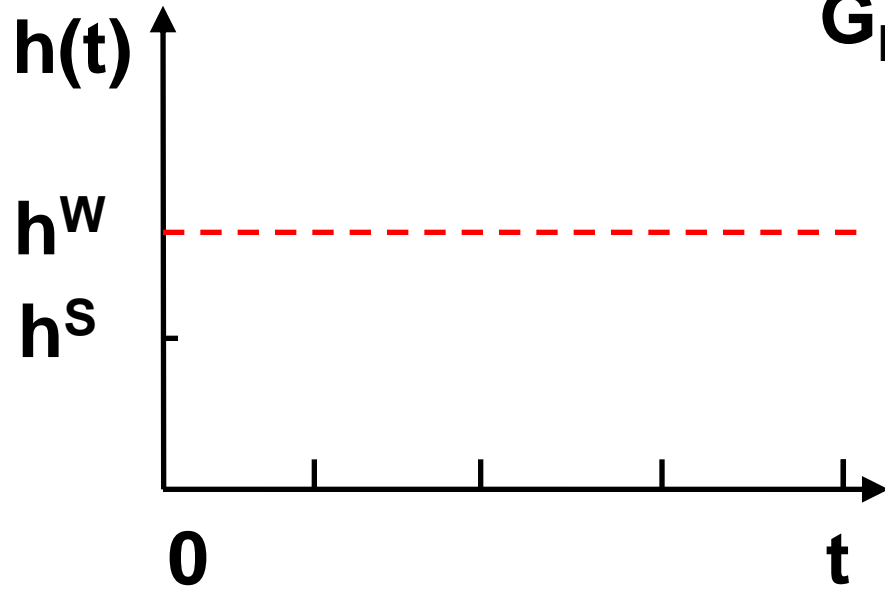

Zákon riadenia

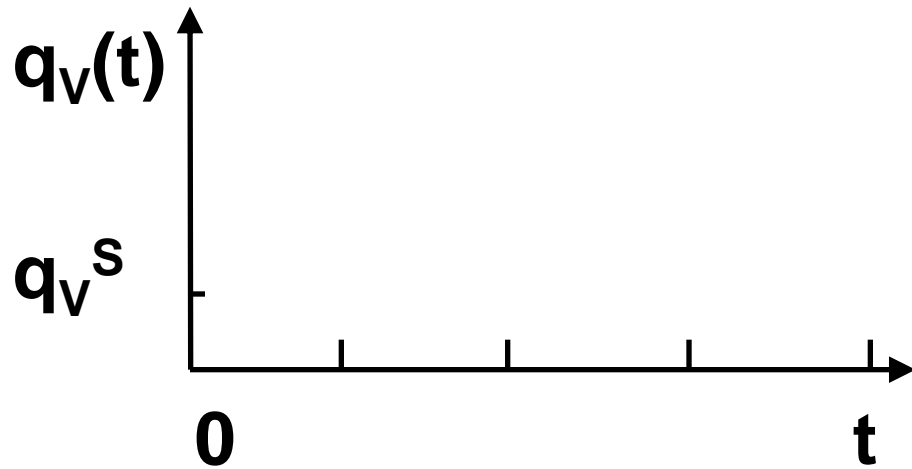
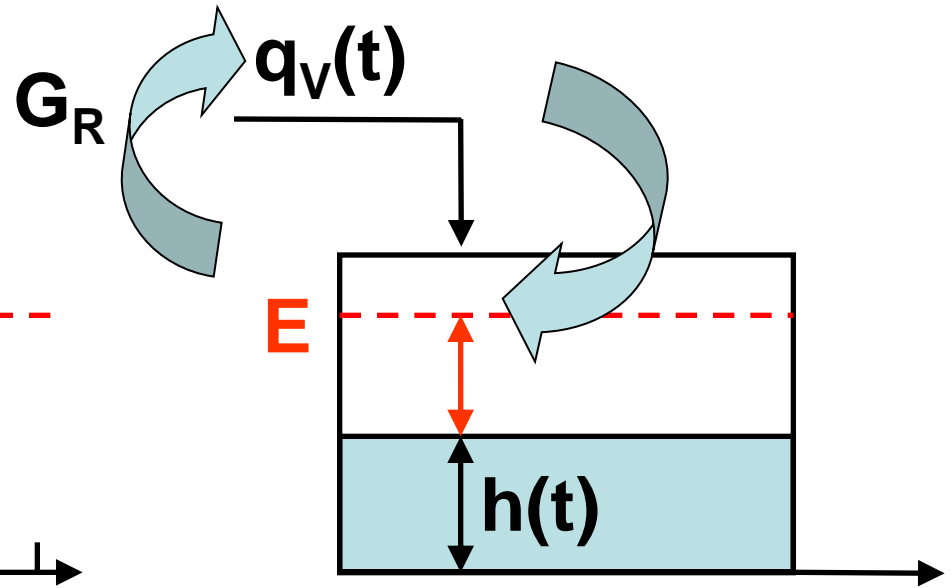
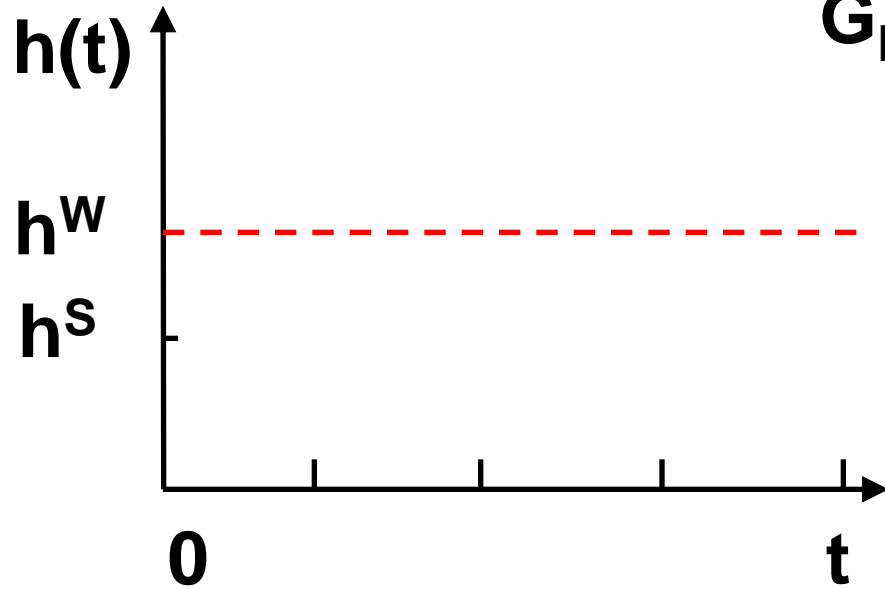

Zákon riadenia

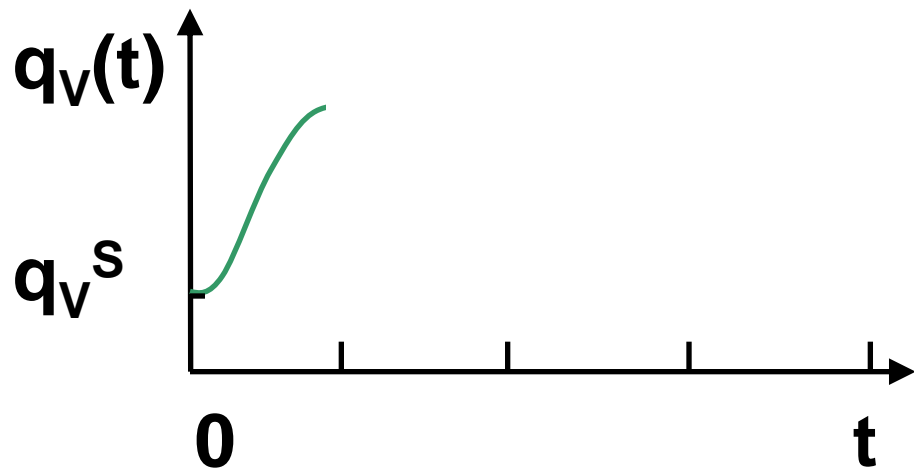
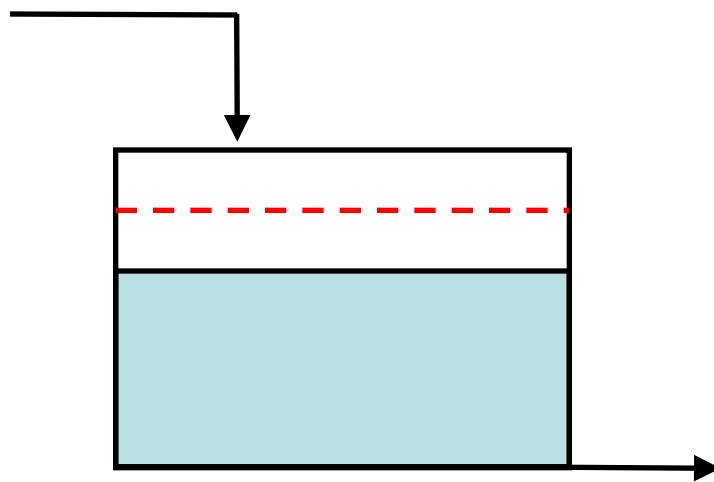
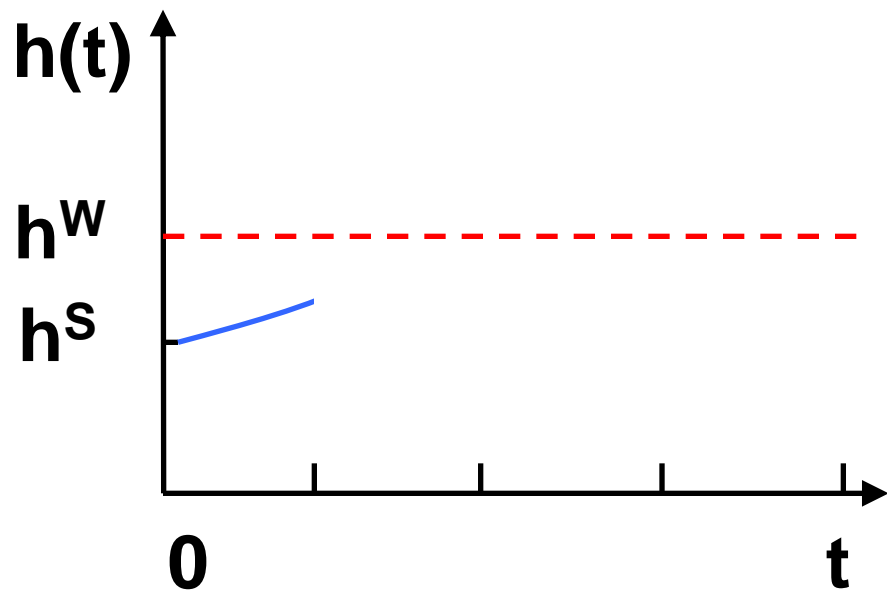

Zákon riadenia

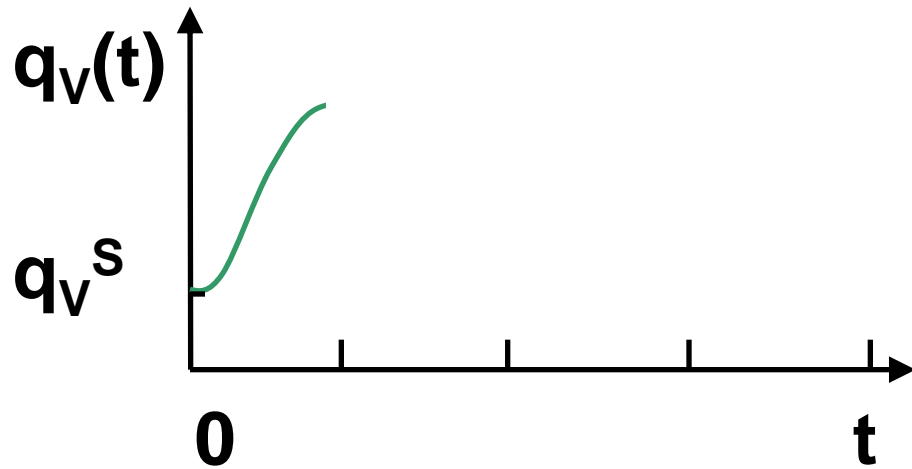
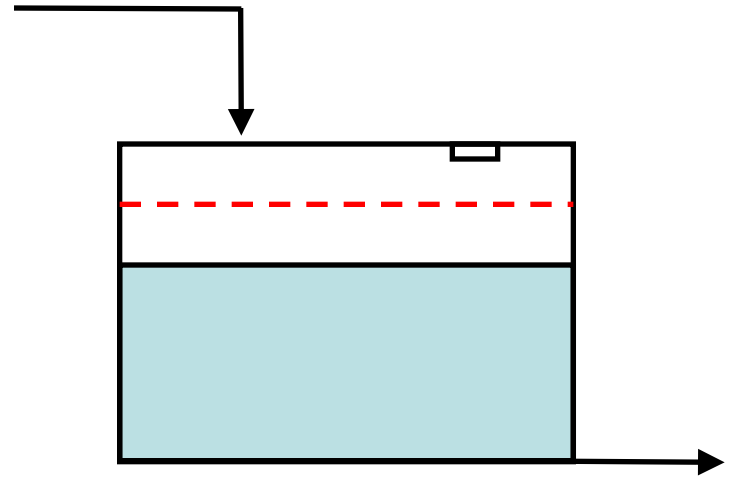
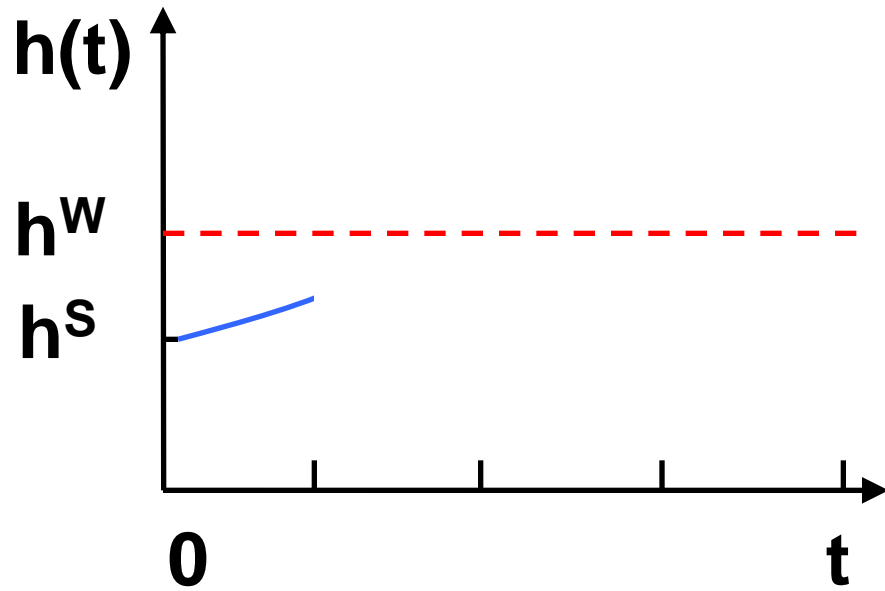

Zákon riadenia

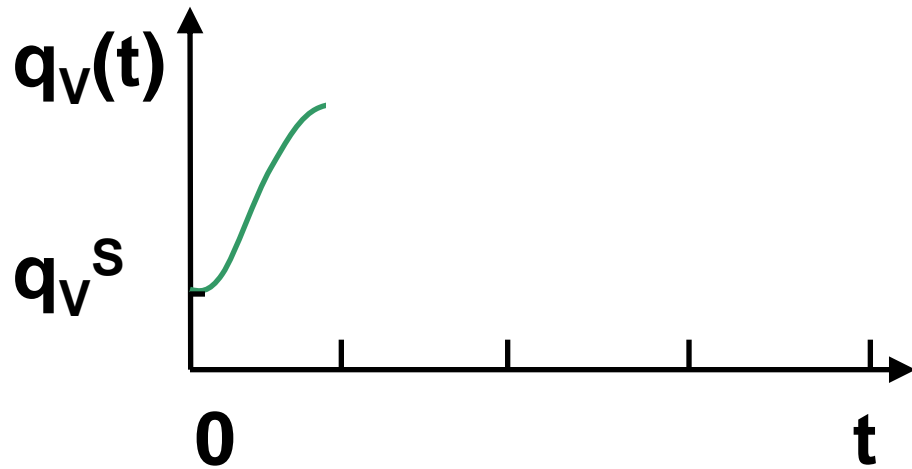
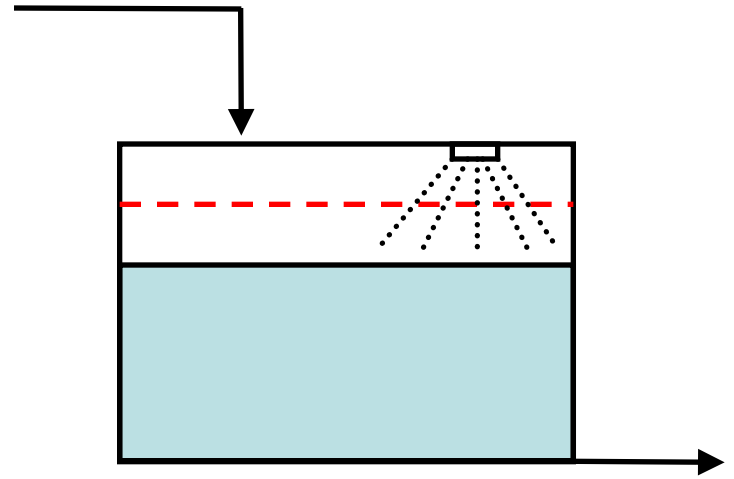
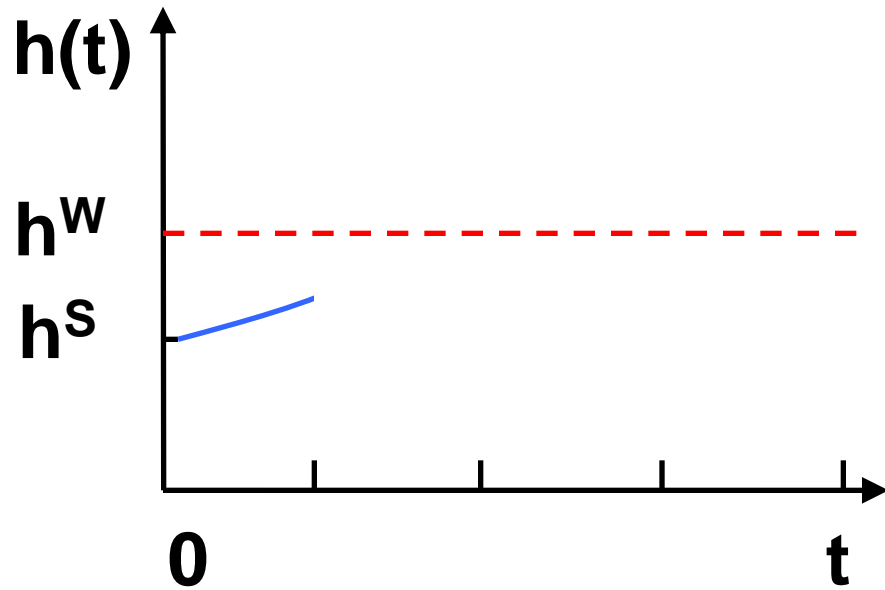

Zákon riadenia

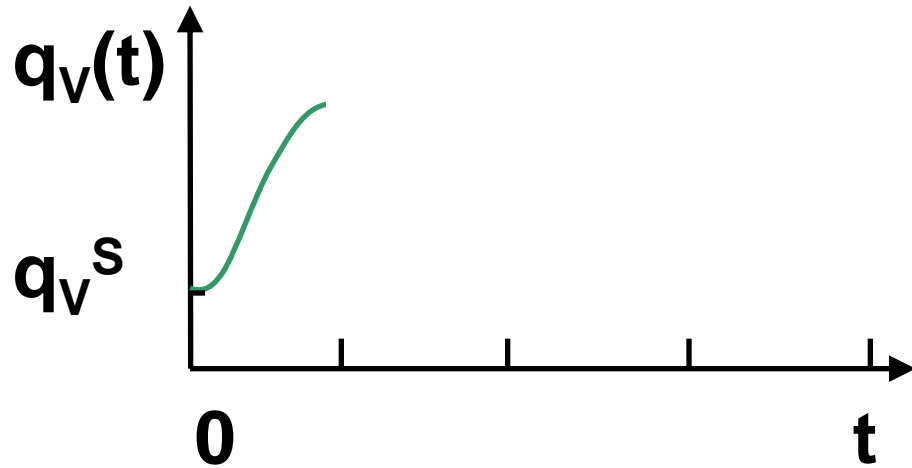
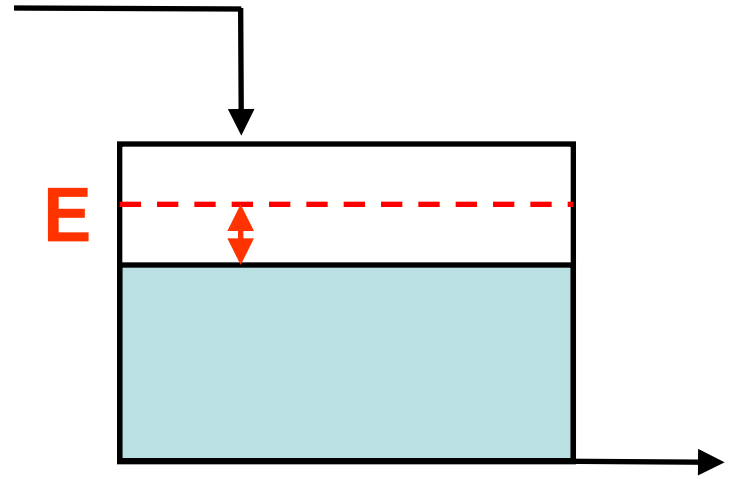
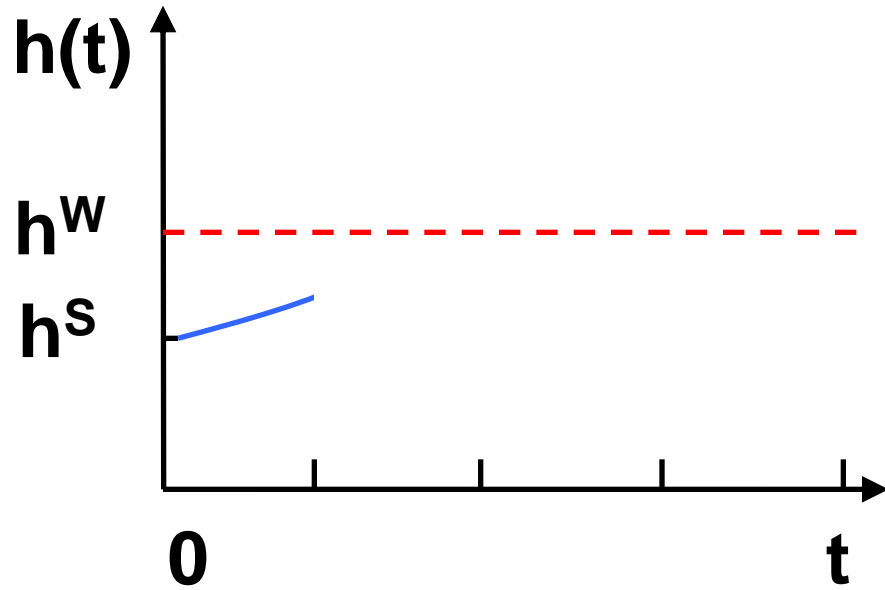

Zákon riadenia

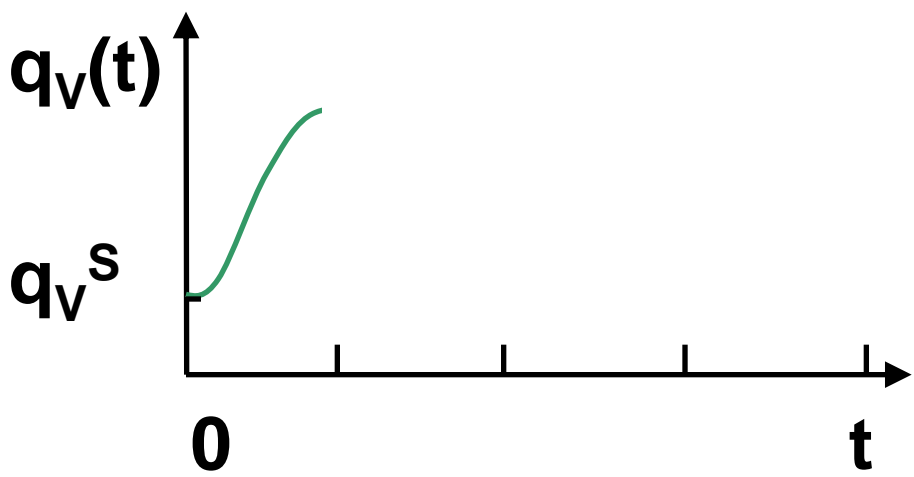
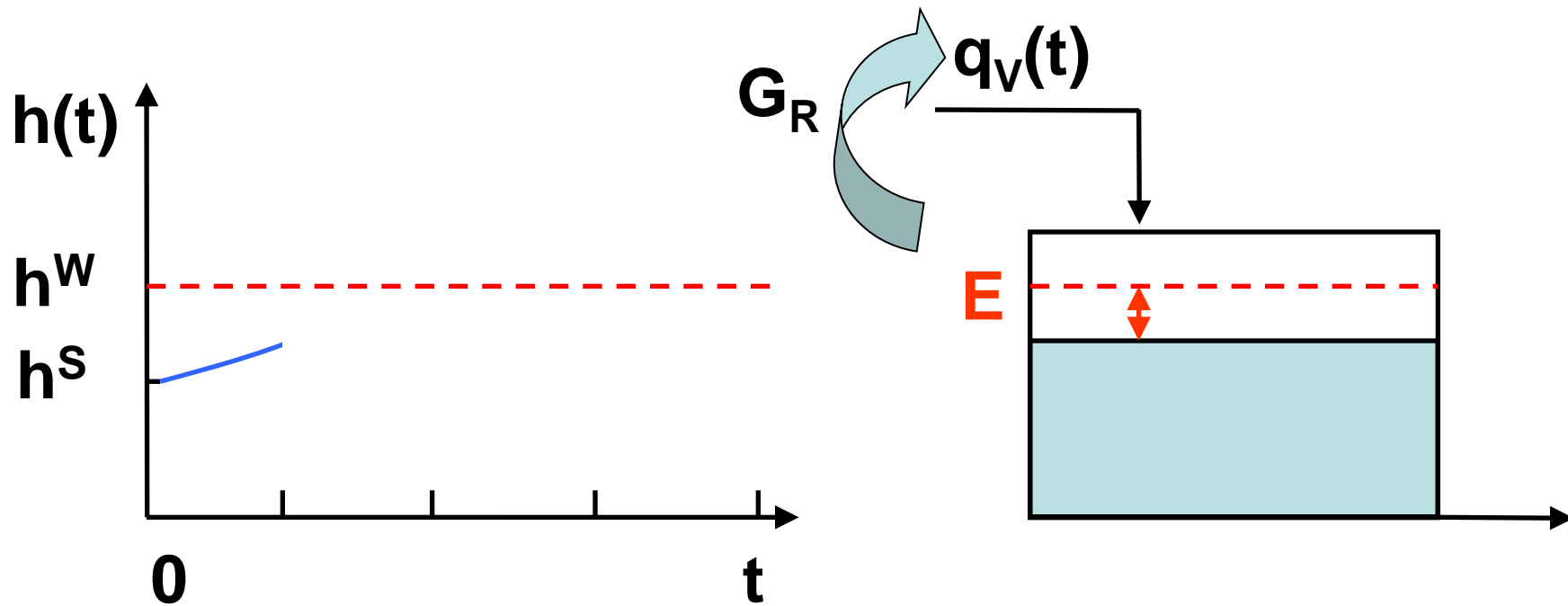

Zákon riadenia

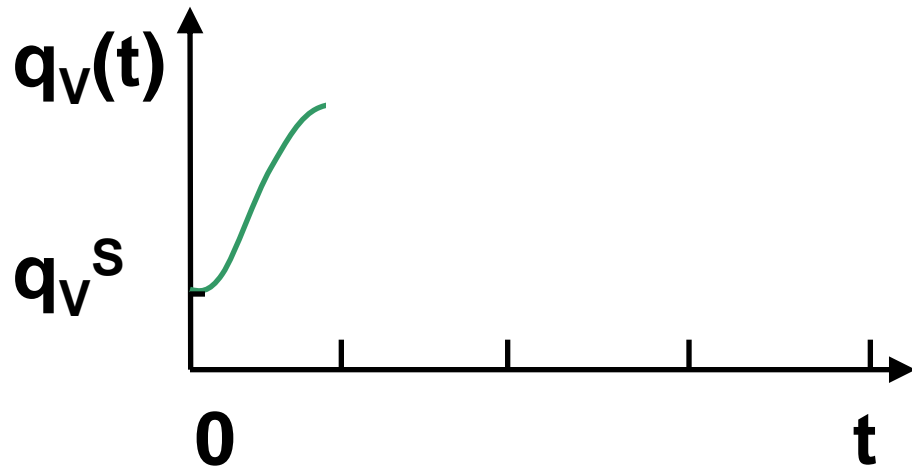
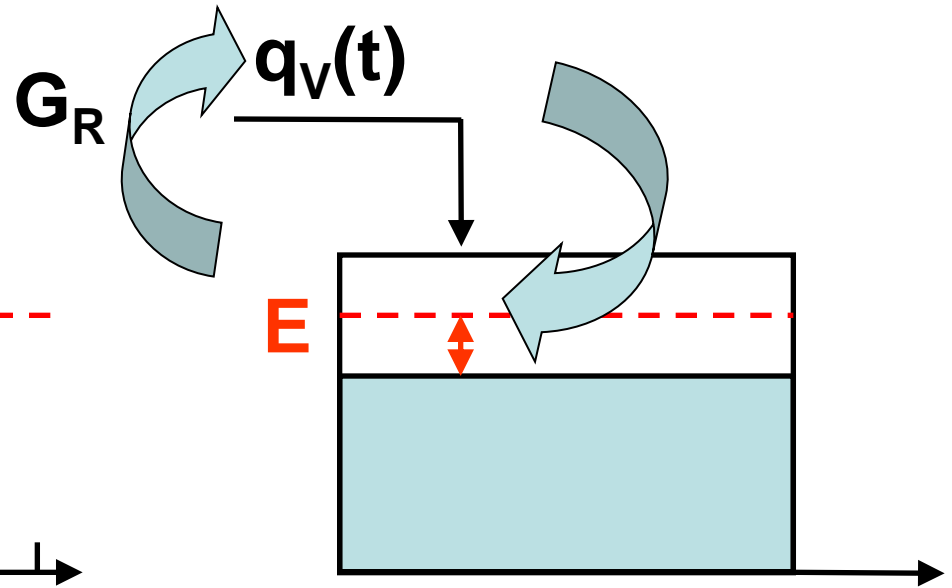
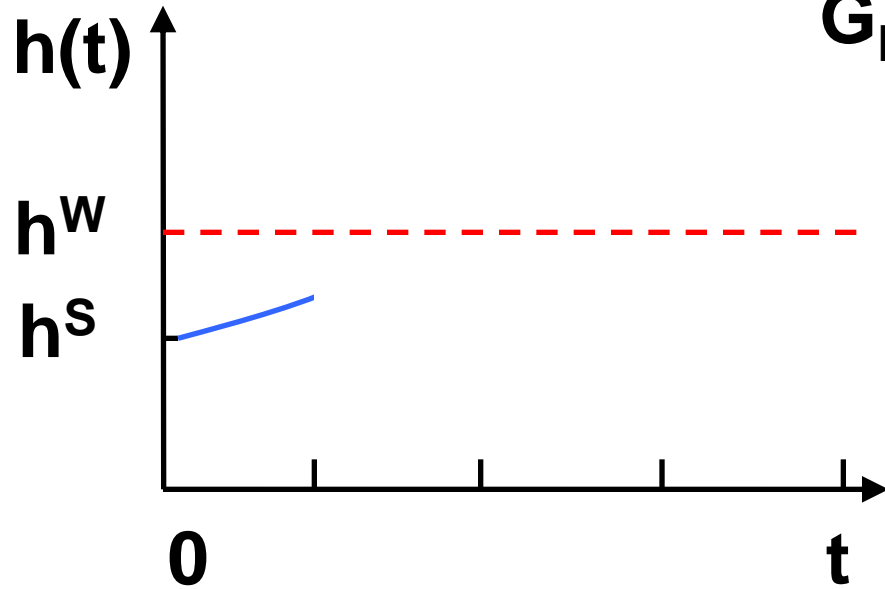

Zákon riadenia

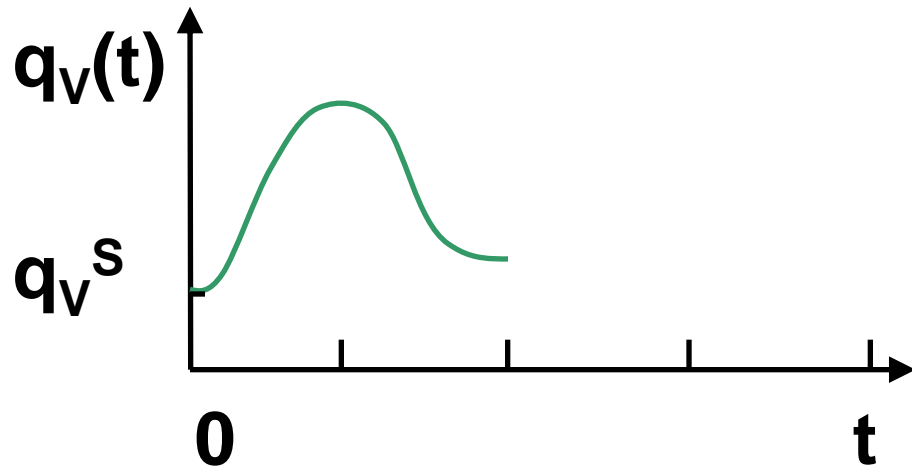
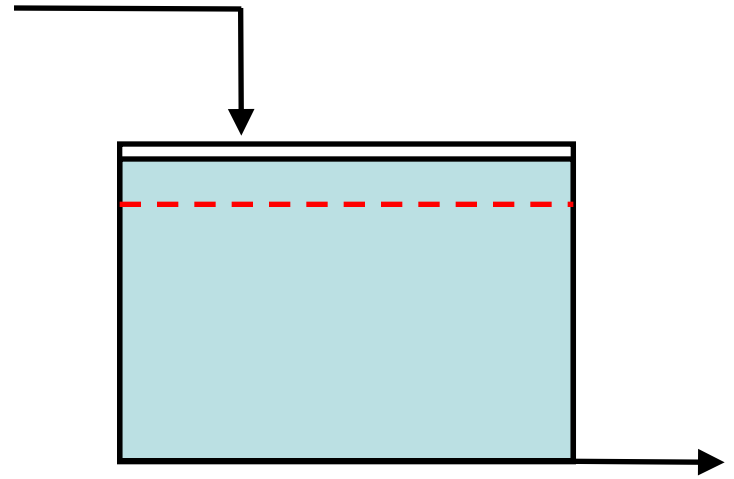
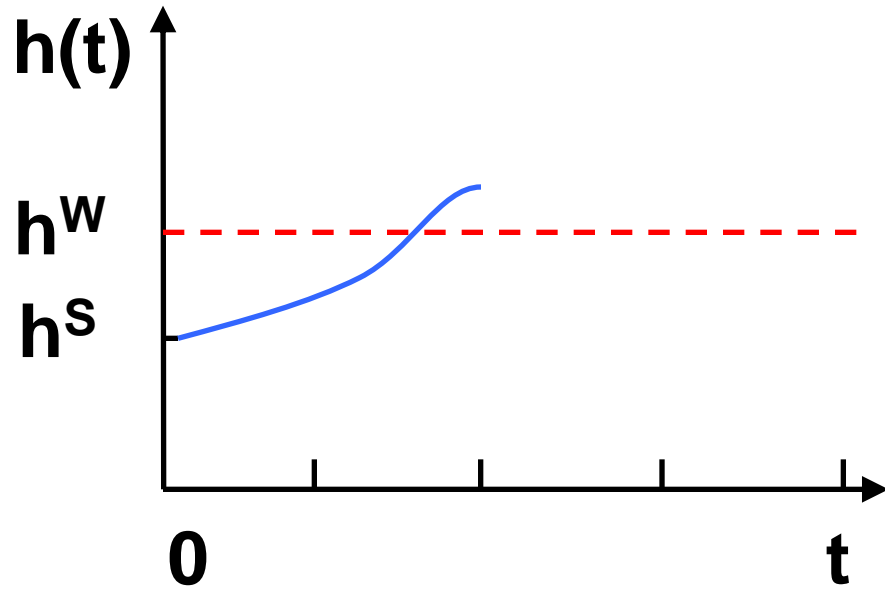

Zákon riadenia

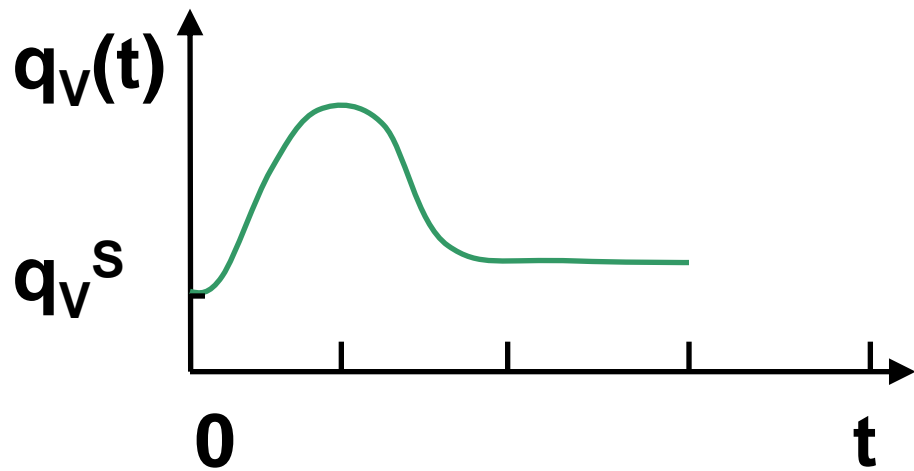
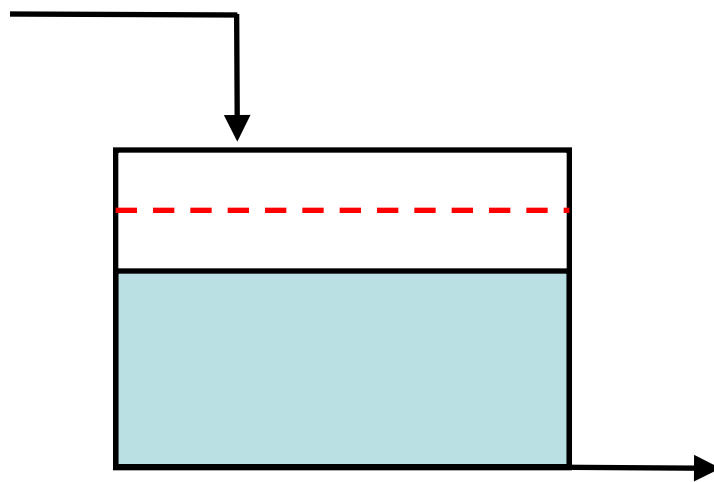
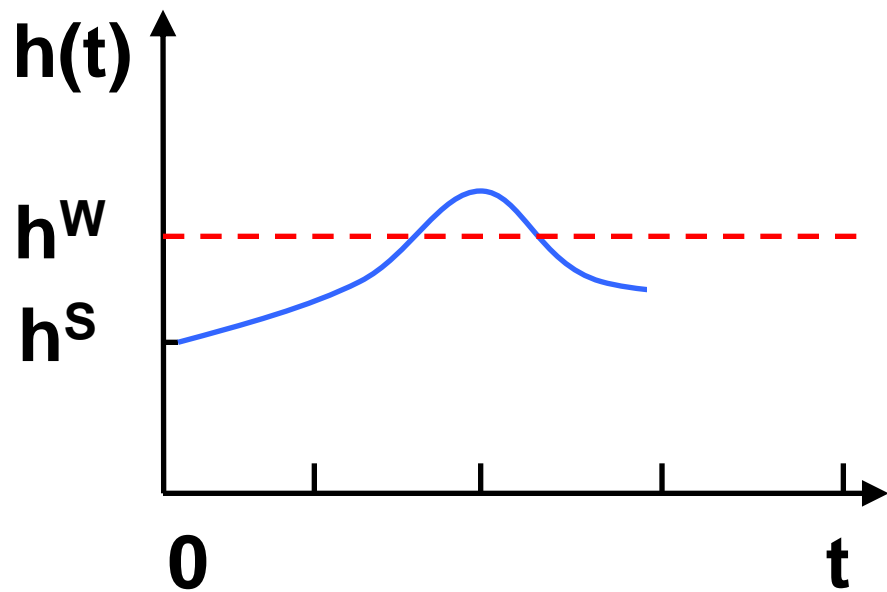

Zákon riadenia

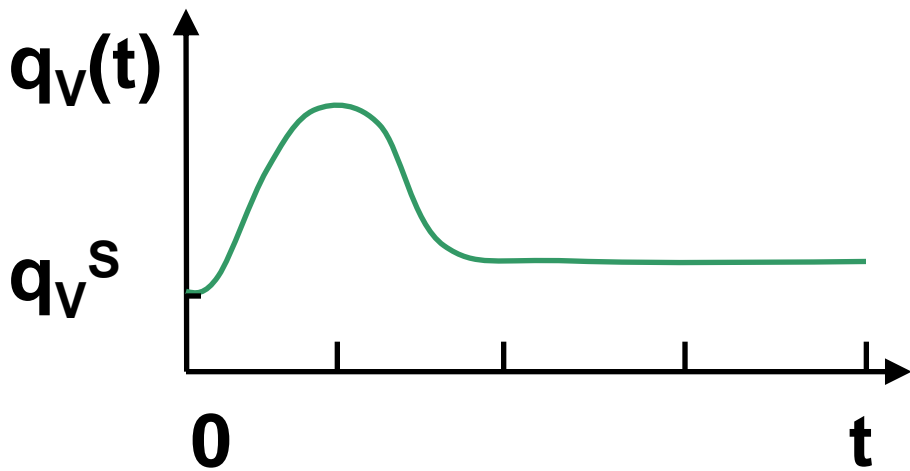
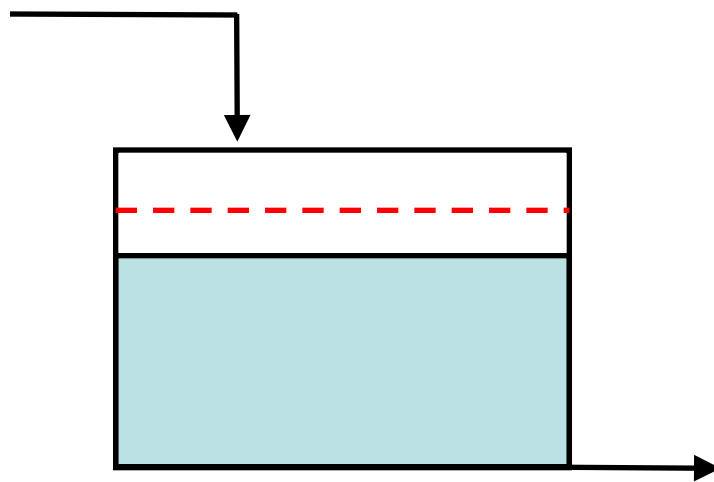
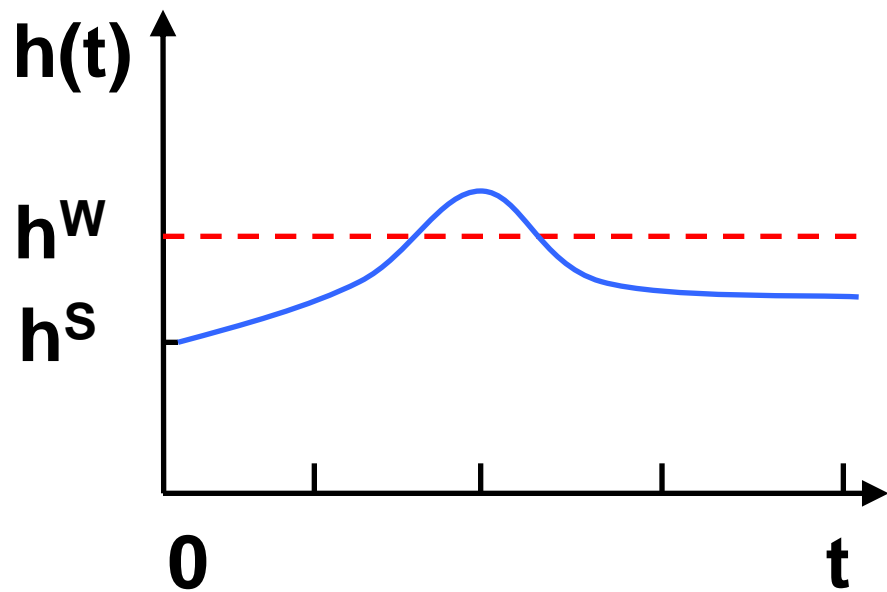

Zákon riadenia

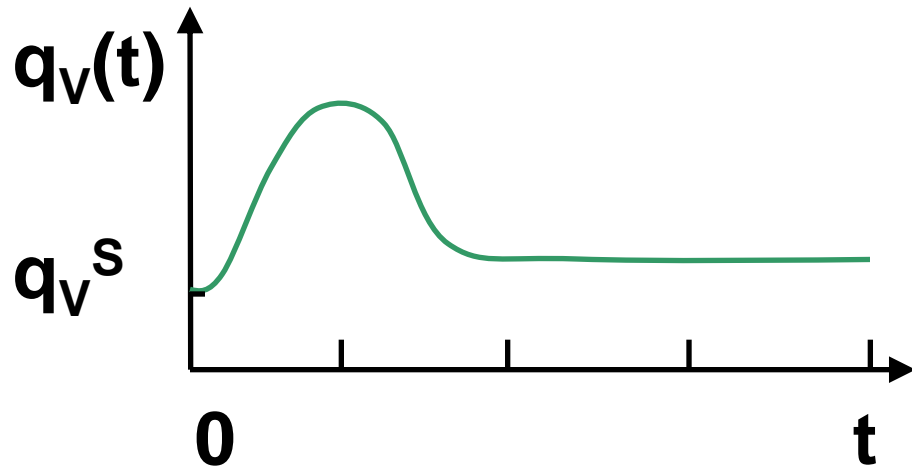
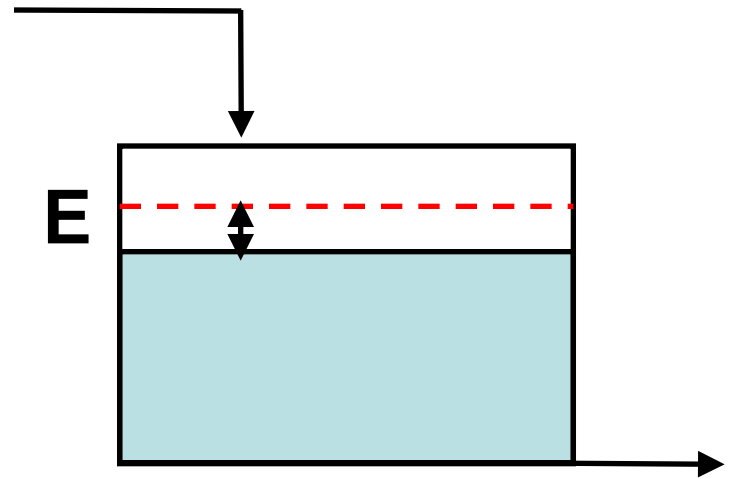
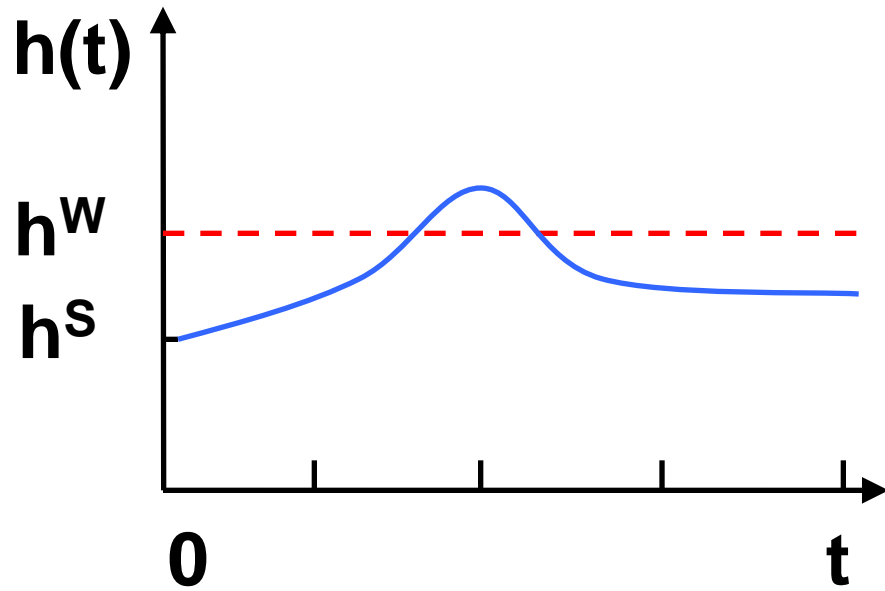

Zákon riadenia

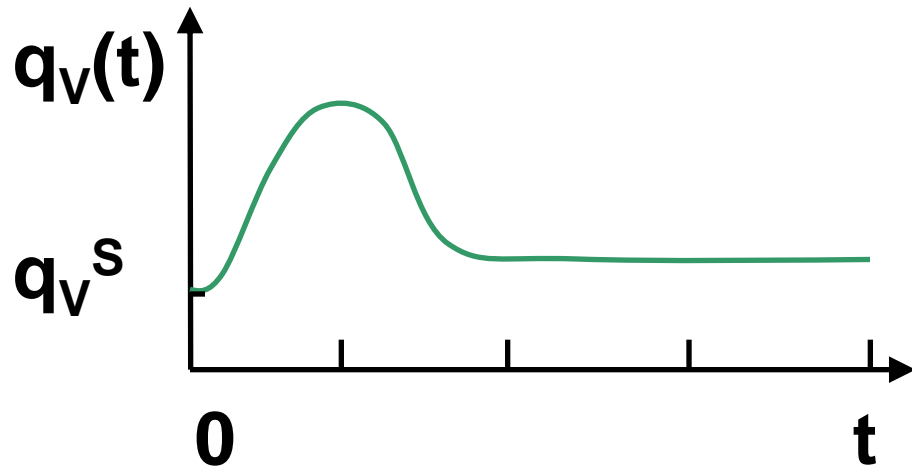
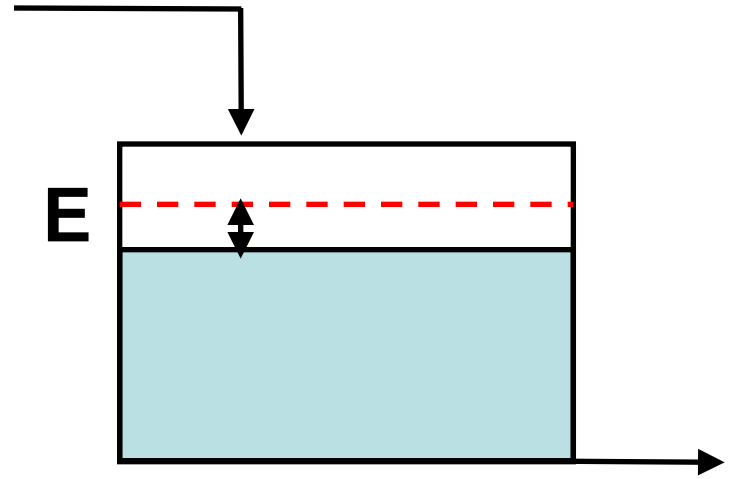
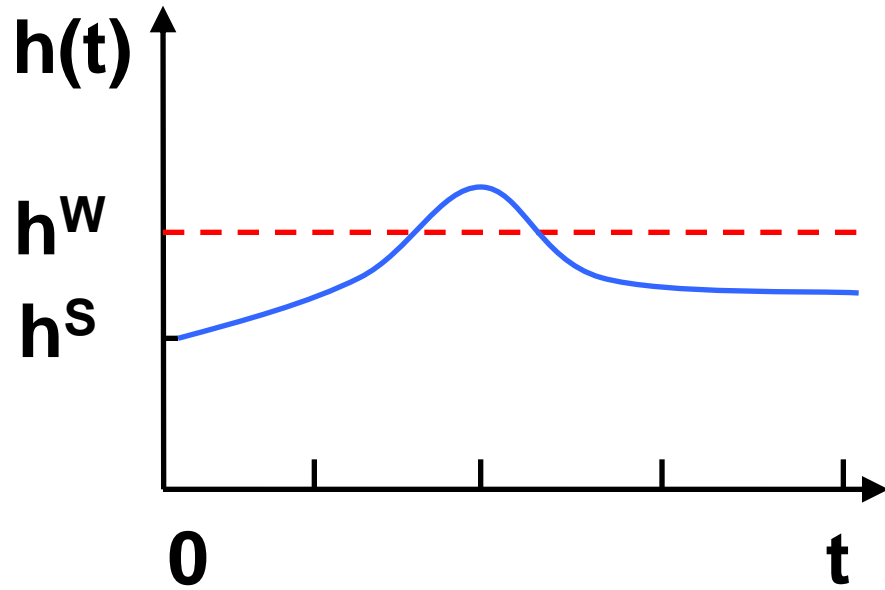

$$E = W - Y$$

Zákon riadenia

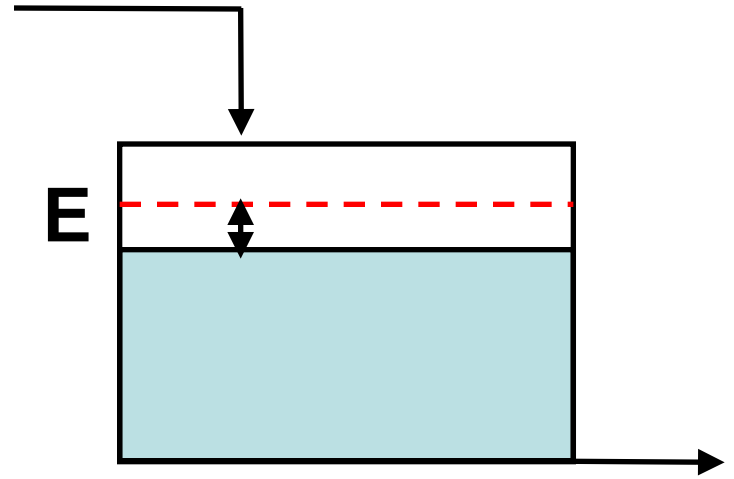
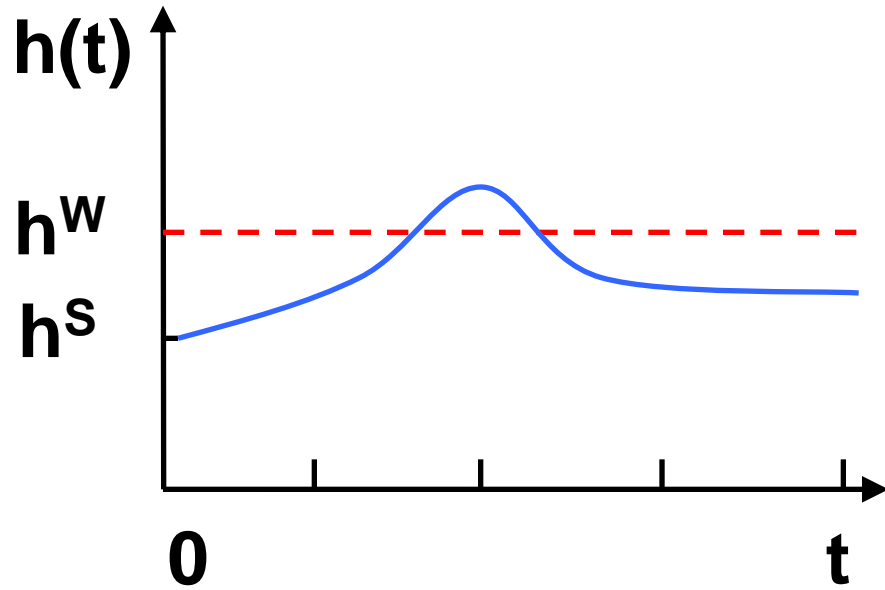

$$E(\infty) = W(\infty) - Y(\infty)$$

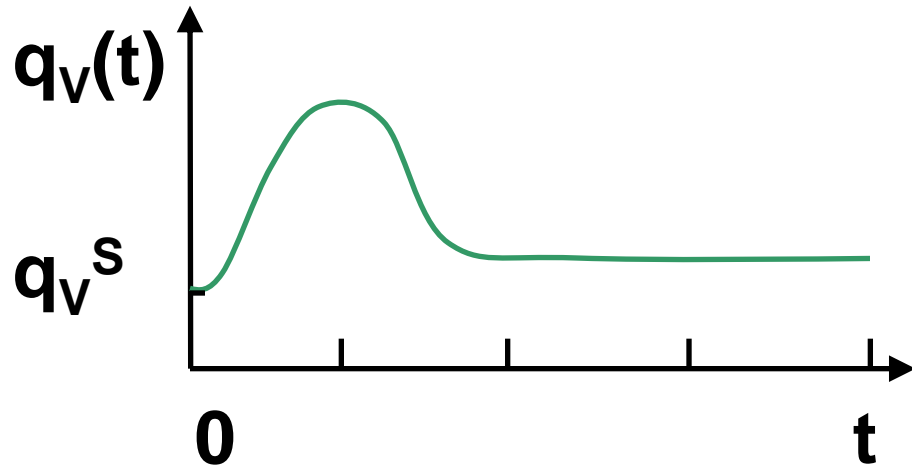

Zákon riadenia

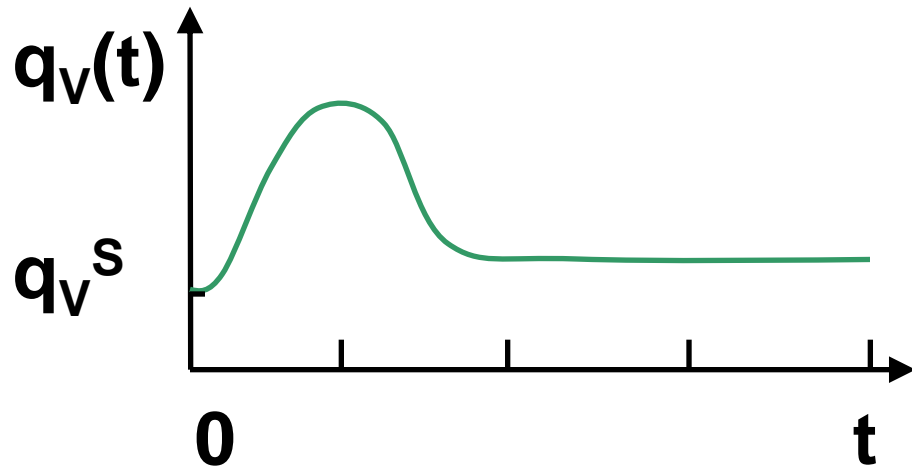
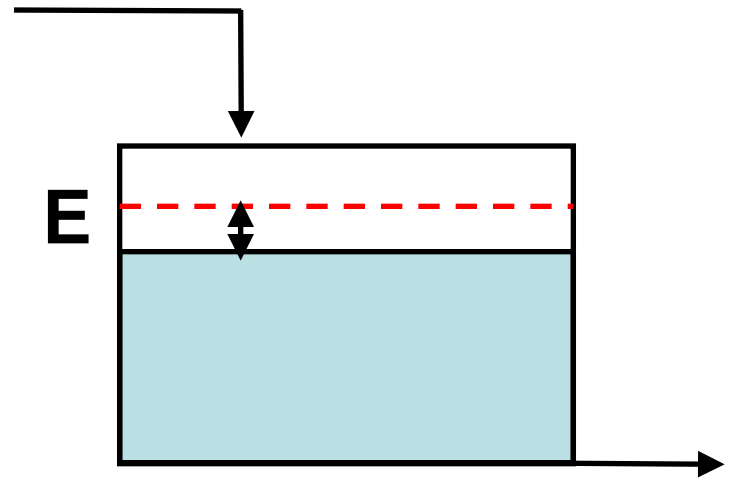
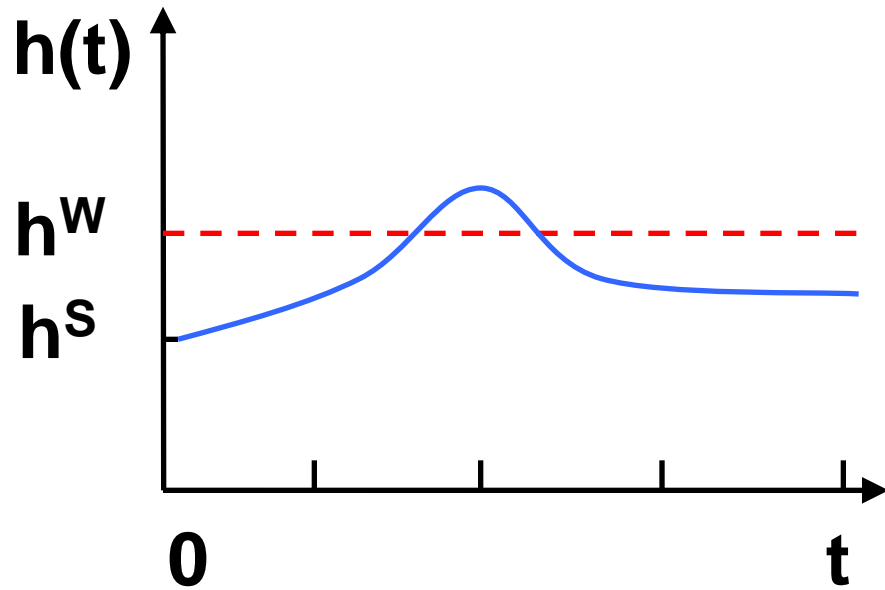

$$\text{TRO: } E(\infty) = W(\infty) - Y(\infty)$$

Zákon riadenia

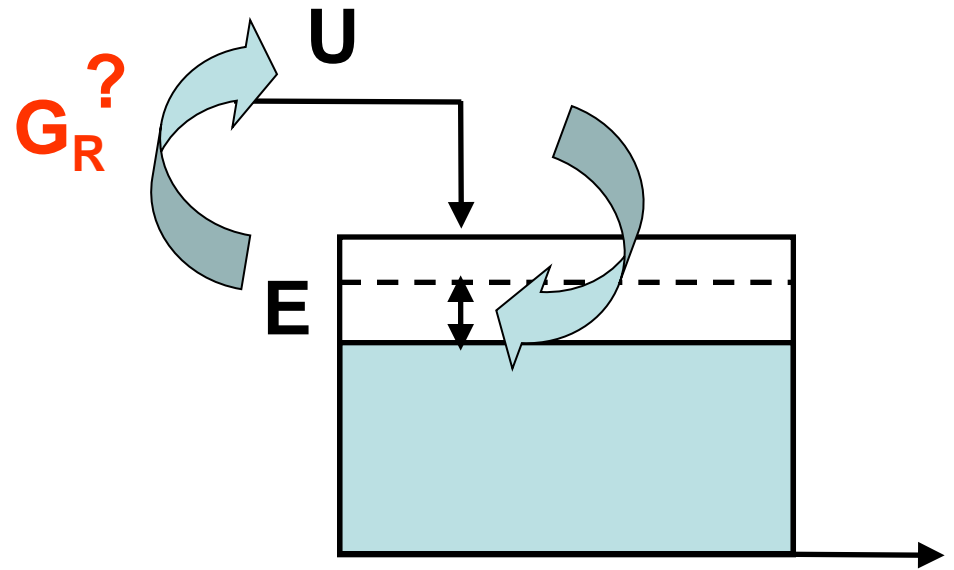

Zákon riadenia

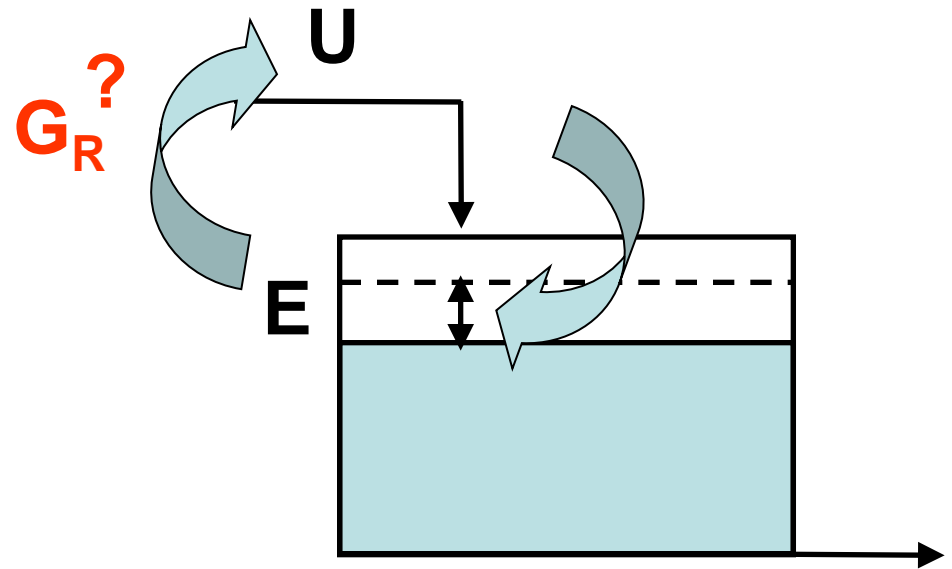

fyzické dynamické zariadenie, ktoré na základe regulačnej odchýlky vypočíta veľkosť akčného zásahu tak, aby výsledná regulačná odchýlka bola čo najmenšia

Zákon riadenia

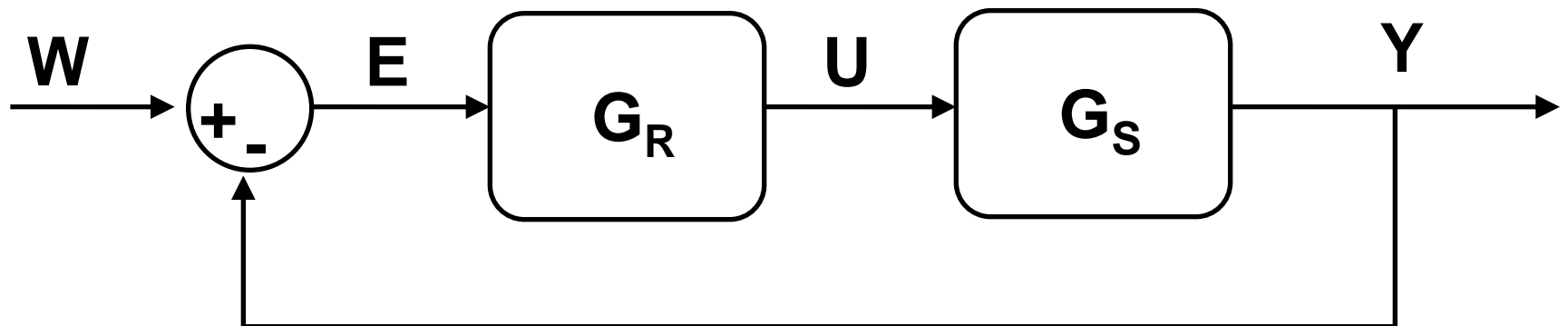

Zákon riadenia

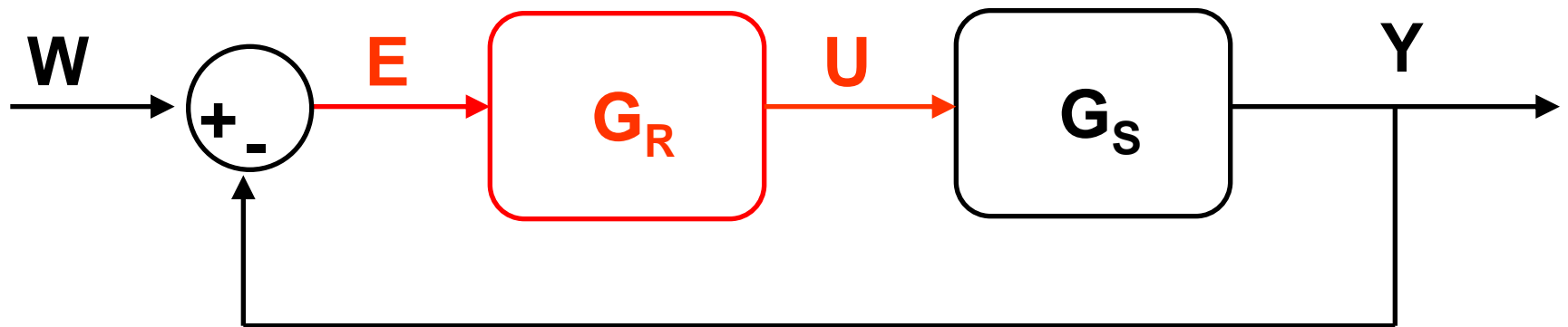

Zákon riadenia

$$U = G_R E$$

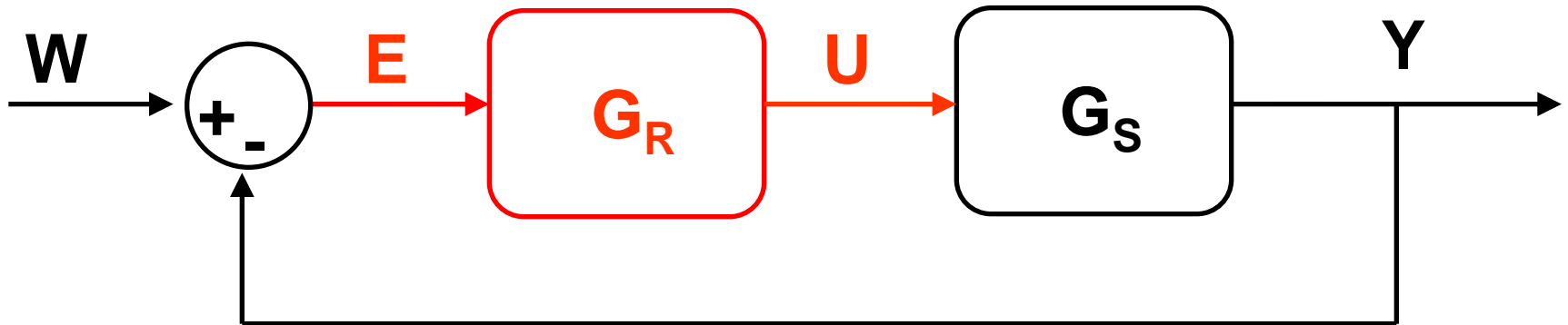

Zákon riadenia

$$u(t) = G_R e(t)$$

Zákon riadenia

- **Proporcionálny regulátor:**

$$u(t) = G_{R,P}e(t)$$

Zákon riadenia

- **Proporcionálny regulátor:**

$$u(t) = G_{R,P} e(t)$$

- **Prenos:**

$$G_{R,P} = Z_R$$

- **Zákon riadenia:**

$$u(t) = Z_R e(t)$$

Zákon riadenia

- **Proporcionálno-integračný regulátor:**

$$u(t) = G_{R,PI} e(t)$$

Zákon riadenia

- **Proporcionálno-integračný regulátor:**

$$u(t) = G_{R,PI} e(t)$$

- **Prenos:**
$$G_{R,PI} = \frac{Z_R s + \frac{Z_R}{T_I}}{s}$$

- **Zákon riadenia:**

$$u(t) = Z_R e(t) + \frac{Z_R}{T_I} \int_0^t e(\tau) d\tau$$

Zákon riadenia

- **Proporcionálno-integračný regulátor:**

$$u(t) = G_{R,PI} e(t)$$

- **Prenos:**
$$G_{R,PI} = \frac{Z_R s + \frac{Z_R}{T_I}}{s}$$

- **Zákon riadenia:**

$$u(t) = u_P(t) + u_I(t)$$

Zákon riadenia

- **Proporcionálno-integračný regulátor:**

$$u(t) = G_{R,PI} e(t)$$

- **Prenos:**
$$G_{R,PI} = \frac{Z_R s + \frac{Z_R}{T_I}}{s}$$

- **Zákon riadenia:**

$$u_I(t) = \frac{Z_R}{T_I} \int_0^t e(\tau) d\tau$$

Zákon riadenia

- **Proporcionálno-integračný regulátor:**

$$u(t) = G_{R,PI} e(t)$$

- **Prenos:**
$$G_{R,PI} = \frac{Z_R s + \frac{Z_R}{T_I}}{s}$$

- **Zákon riadenia:**

$$\frac{du_I(t)}{dt} = \frac{Z_R}{T_I} e(t)$$

Zákon riadenia

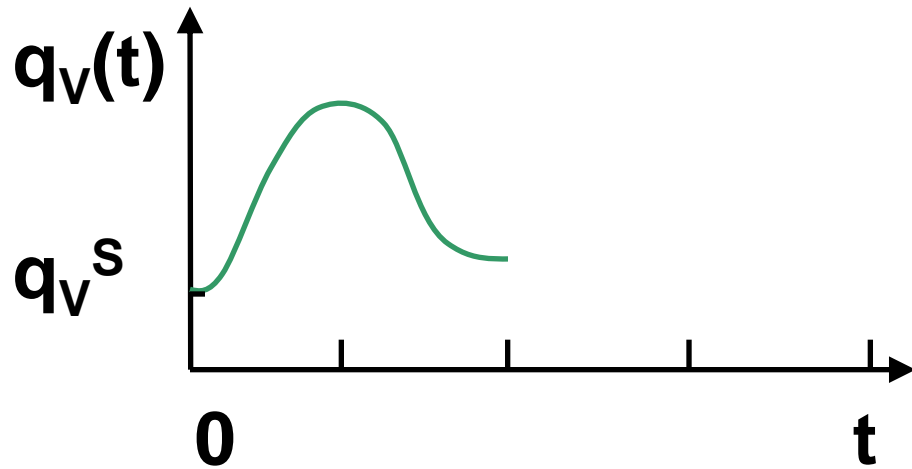
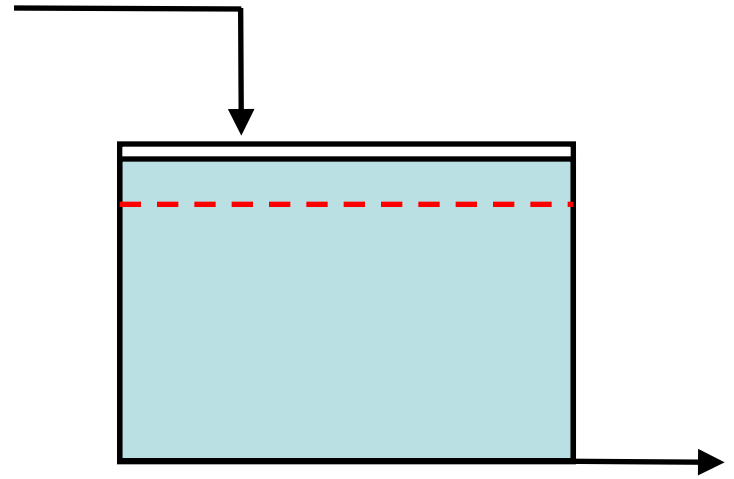
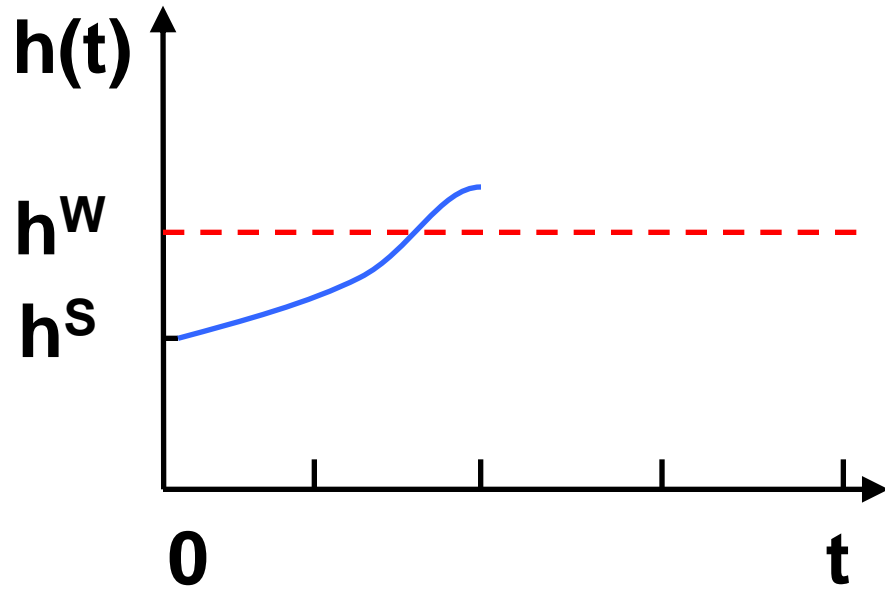

Zákon riadenia

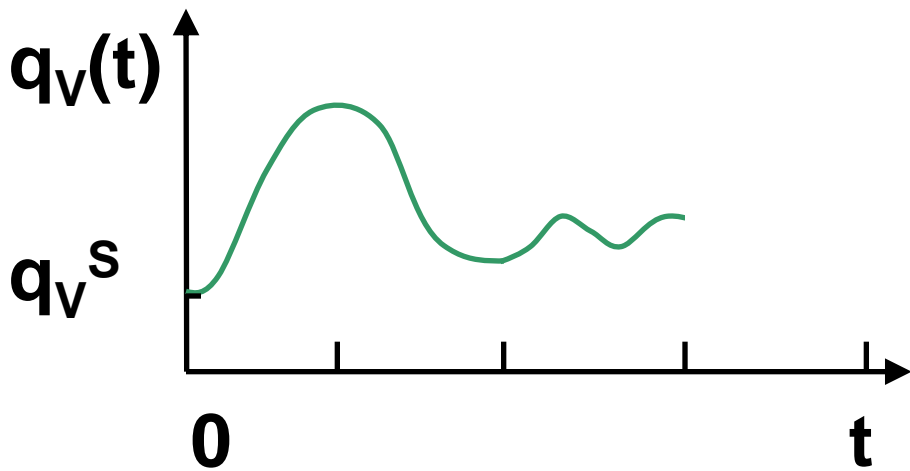
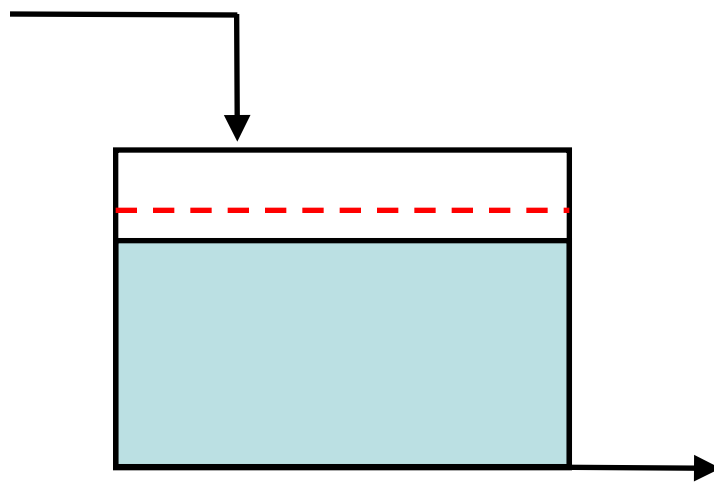
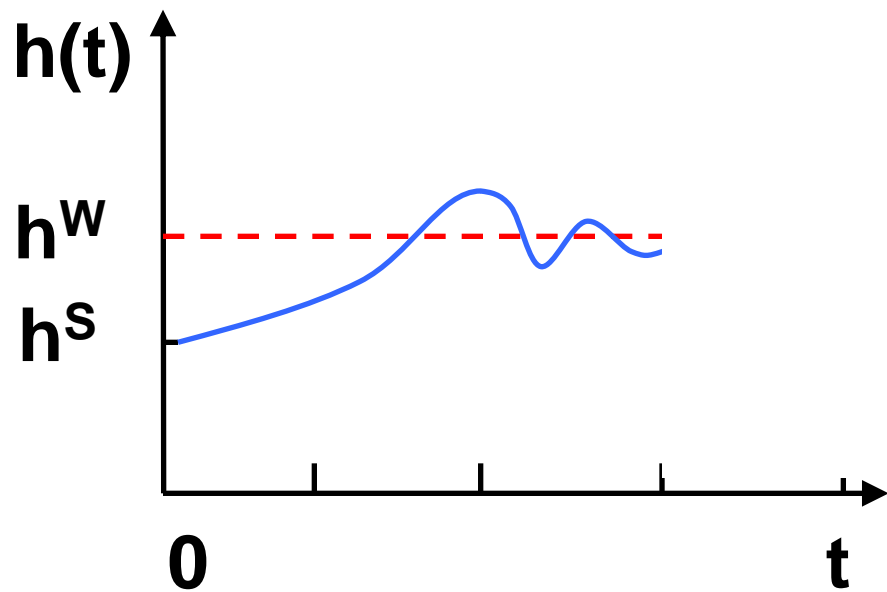

Zákon riadenia

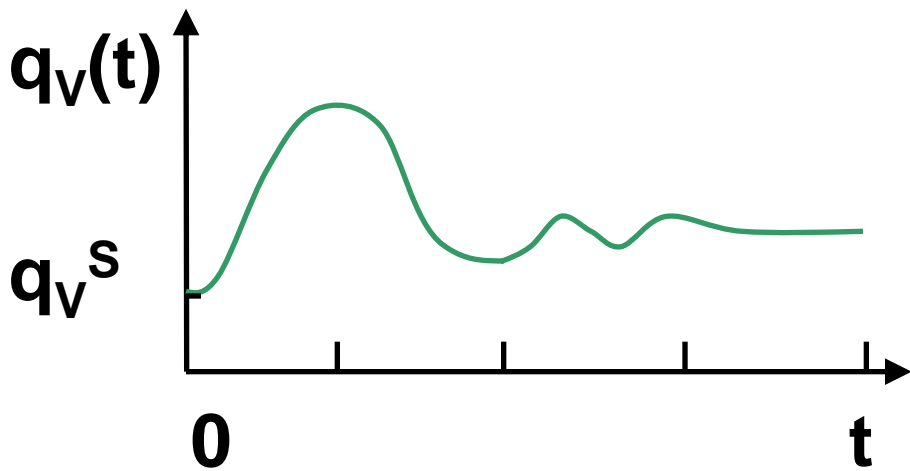
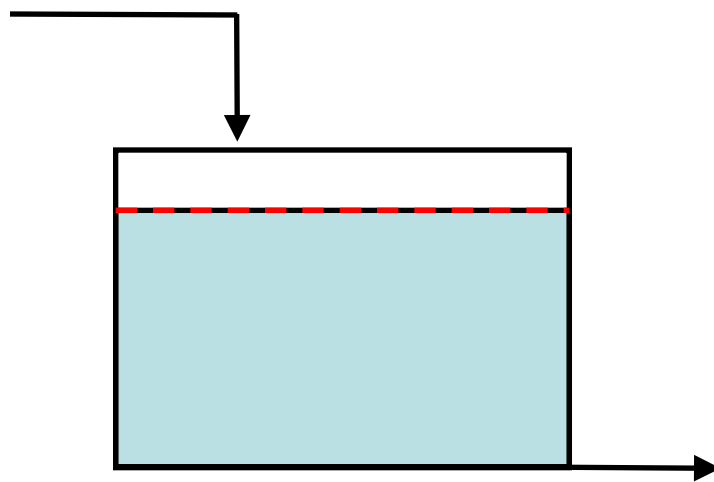
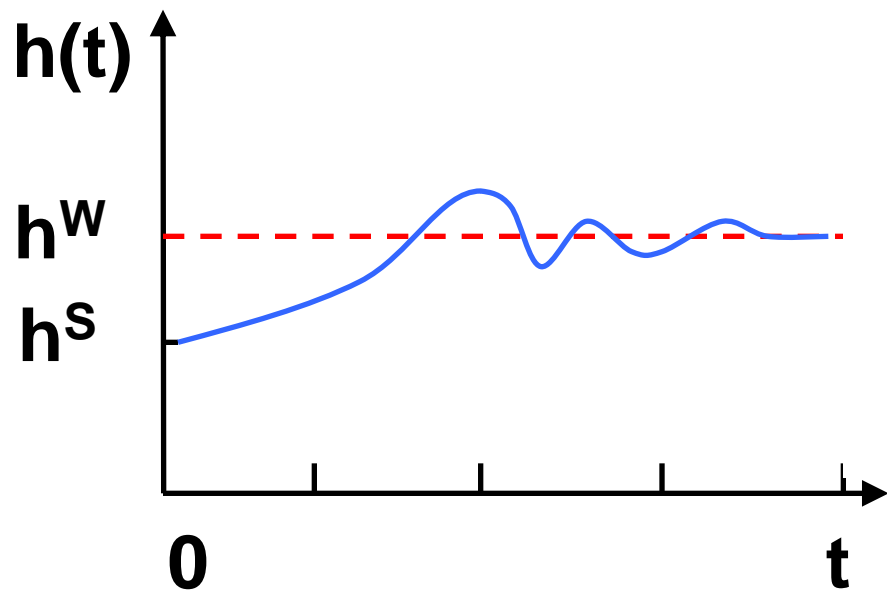

Zákon riadenia

- **Proporcionálno-integračno derivačný regulátor:**

$$u(t) = G_{R,PID} e(t)$$

Zákon riadenia

- **Proporcionálno-integračno derivačný regulátor:**

$$u(t) = G_{R,PID} e(t)$$

- **Prenos:**

$$G_{R,PID} = \frac{Z_R s + \frac{Z_R}{T_I} + Z_R T_D s^2}{s}$$

- **Zákon riadenia:**

$$u(t) = Z_R e(t) + \frac{Z_R}{T_I} \int_0^t e(\tau) d\tau + Z_R T_D \frac{de(t)}{dt}$$

Zákon riadenia

- **Proporcionálno-derivačný regulátor:**

$$u(t) = G_{R,PD} e(t)$$

- **Prenos:** $G_{R,PD} = \frac{Z_R s + Z_R T_D s^2}{s}$

- **Zákon riadenia:**

$$u(t) = Z_R e(t) + Z_R T_D \frac{de(t)}{dt}$$

Zákon riadenia

- **Proporcionálno-derivačný regulátor:**

$$u(t) = G_{R,PD} e(t)$$

- **Prenos:** $G_{R,PD} = Z_R + Z_R T_D s$

- **Zákon riadenia:**

$$u(t) = Z_R e(t) + Z_R T_D \frac{de(t)}{dt}$$

Zákon riadenia

- **Proporcionálno-derivačný regulátor:**

$$u(t) = G_{R,PD} e(t)$$

- **Prenos:** $G_{R,PD} = Z_R + Z_R T_D s$

- **Zákon riadenia:**

$$u(t) = u_P(t) + u_D(t)$$

Zákon riadenia

- **Proporcionálno-derivačný regulátor:**

$$u(t) = G_{R,PD} e(t)$$

- **Prenos:** $G_{R,PD} = Z_R + Z_R T_D s$

- **Zákon riadenia:**

$$u_D(t) = Z_R T_D \frac{de(t)}{dt}$$

Zákon riadenia

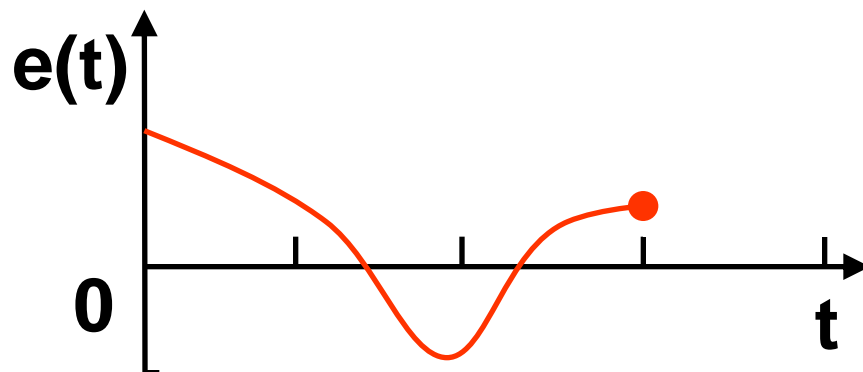
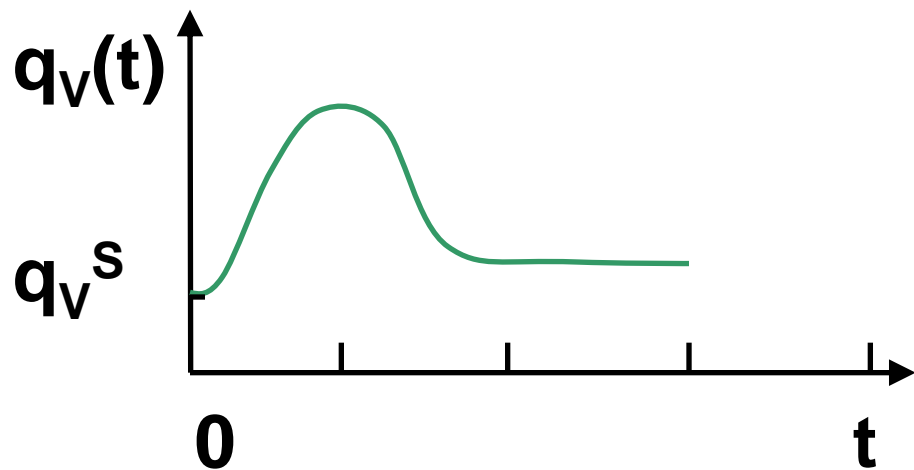
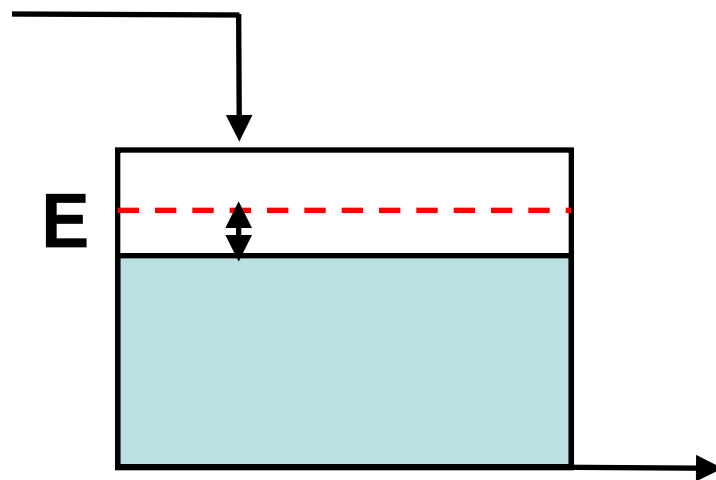
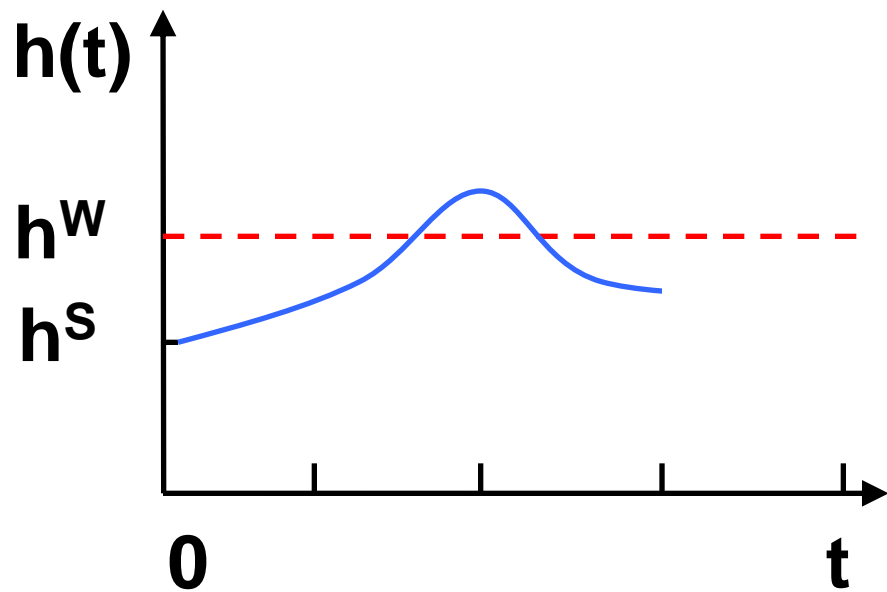

Zákon riadenia

